



STANDARD

C1208D/C1208DS/C1208DA

144 MHz FM TRANSCEIVER

C4208D/C4208DS/C4208DA

430 MHz FM TRANSCEIVER

OWNER'S MANUAL

Thank you for choosing our transceiver.
To use the transceiver correctly,
Please read this manual thoroughly before use.
Keep this manual handy for future reference.

From page 3:

INSTALLATION INSTRUCTIONS

From page 9:

BASIC OPERATION

From page 19:

ADVANCED OPERATION

From page 27:

MEMORY FUNCTIONS

From page 33:

SCANNING

From page 41:

OPERATION AS A REPEATER

From page 47:

ADDITIONAL FEATURES

From page 51:

USING OPTIONS

From page 67:

REFERENCES





MARANTZ JAPAN, INC.

This page intentionally left blank.

HOW TO READ THIS MANUAL

- This manual provides descriptions in this manual are based on configuration of the transceiver as delivered from the factory.
- This manual describes the Models C1208D/C1208DS/C1208DA and C4208D/C4208DS/C4208DA, centering around the C1208DS.

◆ The following symbols are used in this manual.

-  Indicates what you should beware of or observe.
-  Indicates the useful information or an advice.
-  Indicates an operation with the function key held down or after it is pressed. (Function mode)
-  Indicates the Set mode function. This function allows you to set transceiver to an easier-to-use state.
-  Indicates the page to be referred to.

● After Unpacking, Make Sure That the Following Items Are Included.

1. Instruction manual	1
2. Microphone (CMP844/CMP844A)	1
3. Block diagram	1
3. Transceiver body (Main unit)	1
4. Power cord (red, black), 3.0 m	1
5. Main body fixing bracket	1
6. Mobile bracket setscrews--- 1 set	
Bolt (M4 mm x 8 mm)	4
Bolt (M5 mm x 20 mm)	4
Nut (M5 mm)	4
Washer (M5 mm)	8
Spring washer (M5 mm)	4
Tapping screw (M5 mm x 15 mm)	4
Hexagonal wrench key	1
7. Microphone hanger	1
8. Spare fuse (12 A)	2
9. Tone squelch unit (CTN1200)	1
Attached to only the C1208DA/C4208DA	
10. DTMF unit (CTD1200)	1
Attached to only the C1208DA/C4208DA	

CONTENTS

INSTALLATION INSTRUCTIONS	3	SCANNING	33
INSTALLATION PRECAUTION	4	ABOUT SCANNING	34
Installation Location	4	PREPARING FOR SCAN	35
Dashboard Mounting	4	SCANNING WITHIN 1 MHz (1 MHz SCAN)	36
Power Supply	4	SCANNING THE ENTIRE BANDWIDTH	
MOUNTING THE TRANSCEIVER	5	(ALL-SCAN)	36
Attaching the Mounting Bracket	5	SCANNING FREQUENCIES IN	
Mounting the Transceiver	5	MEMORY (MEMORY SCAN)	38
Connecting the Microphone and External		SCANNING PRIORITIZED MEMORY	
Speaker	7	(PRIORITY SCAN)	38
Extension Cable	7	SCANNING THE MEMORY BY BLOCK	
Attaching the Antenna	8	(BLOCK MEMORY SCAN)	39
BASIC OPERATION	9	SCANNING IN TONE SQUELCH MODE	39
CONTROL NAMES AND FUNCTIONS	10	SELECTING THE SCANNING METHOD	40
TURNING ON THE POWER	13	CHANGING THE WAIT TIME FOR BUSY SCAN .	40
ADJUSTING THE VOLUME	13	OPERATION AS A REPEATER	41
ADJUSTING THE SQUELCH	14	GENERAL INFORMATION	42
TURNING OFF THE SQUELCH	14	SETTING THE REPEATER MODE	43
RECEIVING BAND SELECTION	14	TRANSMITTING A 1750Hz TONE BURST	43
RECEIVING	15	SETTING THE TRANSMIT FREQUENCY	
TRANSMITTING	15	HIGHER THAN RECEIVE FREQUENCY	44
List of Function Mode	16	REVERSING THE REPEATER TRANSMIT/	
ABOUT BEEP SOUND	17	RECEIVE FREQUENCIES	44
ABOUT ATTENUATOR	17	CHANGING THE REPEATER OFFSET	
List of Set Mode Functions	18	FREQUENCY	45
ADVANCED OPERATION	19	CHANGING THE REPEATER TONE FREQUENCY	
CHANGING THE FREQUENCY STEP	20	45
CHANGING THE FREQUENCY STEP TO 1 MHz		SIFTING THE FREQUENCY WITHOUT TONE	
.....	20	ENCODER	46
INPUTTING A FREQUENCY DIRECTLY	21	ADDITIONAL FEATURES	47
CHANGING THE CALLING FREQUENCY	22	PREVENTING UNINTENTIONAL TRANSMISSION	
STORING ASSOCIATED DATA WITH THE		(PTT LOCK)	48
CALLING FREQUENCY	22	SETTING AUTOMATIC END OF TRANSMISSION	
USING THE KEY LOCK	23	(TIME OUT TIMER)	48
DISABLING VOLUME/SQUELCH WHILE IN KEY		ADJUSTING DISPLAY LIGHTING (DIMMER)	49
LOCK	23	CHANGING THE AUDIO MUTING LEVEL	49
CONTROLLING THE SQUELCH WITH RF LEVEL .		CHANGING THE BEEP AUDIO VOLUME	50
.....	24	AM MODE OPERATE	50
CHANGING THE TRANSMIT POWER	25		
TURNING OFF THE POWER AUTOMATICALLY			
.....	26		
RECEIVING IN THE SUB-BAND AND			
TRANSMITTING IN THE MAIN BAND	26		
MEMORY FUNCTIONS	27		
ABOUT MEMORY	28		
STORING OFTEN-USED FREQUENCIES			
IN MEMORY	29		
RECALLING A FREQUENCY FROM MEMORY ...	29		
CHANGING AN OPERATING FREQUENCY			
IN MEMORY	30		
INHIBITING MEMORY MODIFICATION	30		
ERASING DATA AT A SPECIFIC MEMORY			
ADDRESS	31		
ASSIGNING PRIORITY TO MEMORY			
ADDRESSES	31		
ASSIGNING EACH MODE TO MEMORY			
ADDRESSES	32		
COPYING THE MEMORY FREQUENCY TO VFO			
.....	32		

USING OPTIONS	51
ABOUT THE CTN1200 TONE SQUELCH UNIT	52
USING THE TONE ENCODER	52
USING TONE SQUELCH	53
CHANGING THE TONE FREQUENCY	53
ABOUT THE CTD1200 DTMF UNIT	54
INPUTTING ANOTHER PARTY'S PAGING/ SQUELCH CODE	55
SETTING A GROUP CODE	55
PAGING METHOD	56
CHANGING THE TIME REQUIRED FOR PAGING SIGNAL OUTPUT	56
CHANGING THE NUMBER OF PAGING ALERTS	57
USING CODE SQUELCH	57
USING THE DTMF	59
ABOUT ATORING AND DISPLAYING THE DTMF CODE	59
STORING THE DTMF CODE	60
SENDING THE STORED DTMF CODE	60
CHANGING THE DTMF CODE IN MEMORY	61
CONFIRMING THE STORED DTMF CODE	61
ERASING THE STORED DTMF CODE	62
CHANGING THE DTMF CODE SENDING SPEED	62
CHANGING THE DTMF TO A SINGLE TONE	63
USING THE OPTIONAL CABLES (CAW560, CAW561, CAW562, CAW575, CAW576)	64
9,600 bps HIGH-SPEED PACKET OPERATION (G3RUH SYSTEM)	65
1,200 bps PACKET OPERATION	66
 REFERENCES	 67
TROUBLESHOOTING	68
INITIALIZATION (RESET)	69
OPTIONS	70
AFTER-SALE SERVICE	70
Specifications	71
INDEX	72

INSTALLATION INSTRUCTIONS

INSTALLATION PRECAUTION	4
Installation Location	4
Dashboard Mounting	4
Power Supply	4
MOUNTING THE TRANSCEIVER	5
Attaching the Mounting Bracket	5
Mounting the Transceiver	5
Connecting the Microphone and External Speaker	7
Extension Cable	7
Attaching the Antenna	8

INSTALLATION PRECAUTION

Installation Location

The following points must be noted regarding location of the transceiver.

1. Avoid a place with high temperature, high humidity or dust.
Avoid a location with direct exposure to sunlight.
Install in a dry and well-ventilated area.
2. In order to maintain the cooling effect of the transceiver's radiating fins, provide sufficient space at back of the transceiver and under it. The transceiver main unit may get warm if it is used for a long period of time. This is normal.

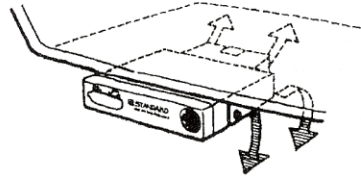
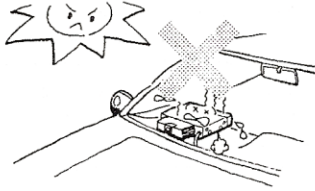

Dashboard Mounting

1. It is recommended that the transceiver be mounted under the dashboard, at the side of the glove box or under the instrument panel.
2. Attach the transceiver so that the back of the transceiver does not touch any material that could melt or be deformed by the heat of the transceiver.
Install the transceiver in a place as free of vibration as much as possible.

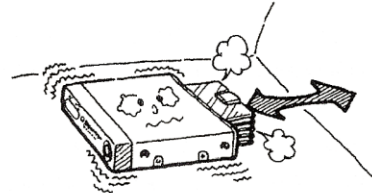
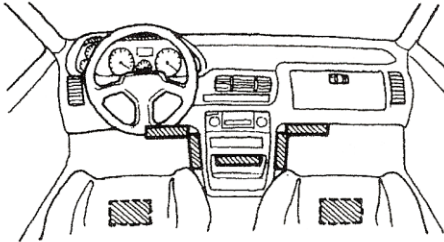

CAUTION Never install the transceiver in the following places:

- Near air conditioner outlet vents
- Places exposed to direct sunlight
- Places with extensive vibration
- Near electronic circuits
- Places where the transceiver may affect driving safety

Power Supply

1. The transceiver is designed for automobiles with 12VDC electrical systems. It can not be used for trucks and other types of vehicles with 24VDC electrical systems unless a 24VDC-to-12VDC converter is used.
2. NEVER connect the transceiver to Alternating Current (AC). This will cause irreparable damage to the transceiver.

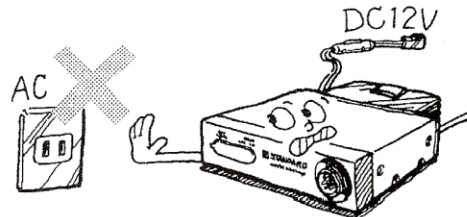
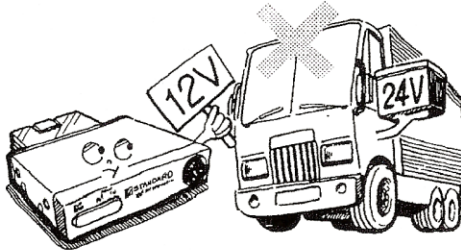

Mounting the Transceiver

Attaching the Mounting Bracket

Attach the mounting bracket in a place where it can be firmly fixed.
Be sure to use the bolts and the screws included.

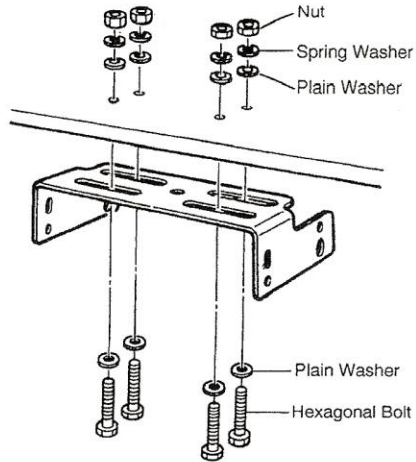

Mounting the Bracket

1 Bore holes of $\phi 5.2 - 5.5\text{mm}$ or M5mm hex-head bolts.

Bore holes of $\phi 4.0 - 4.3\text{mm}$ or M5mm self-tapping screws.

2 Pass the M5mm hex-head bolts through plain washers.

Next, attach the bracket with plain washers, spring washers and nuts from the interior side.

Pass the M5mm self-tapping screws through plain washers and screw in.

Mounting the Transceiver

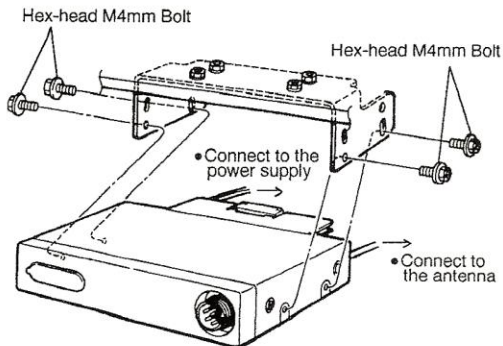

1 Connect the antenna to the coaxial cable connector on the rear panel of the main unit .
Connect the power cable to the 12VDC power supply.

2 Insert the main unit in the mounting bracket and fix it with the M4mm bolts.

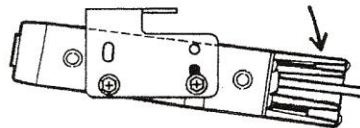
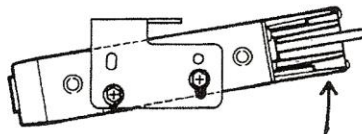

Connecting the Power Supply Cable

In case of automobile's

The transceiver requires power from the automobile's 12VDC battery.

Use the power supply cord in the accessory package to connect the battery to the transceiver.

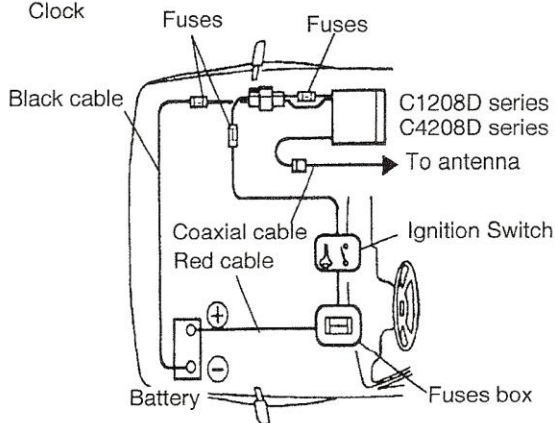
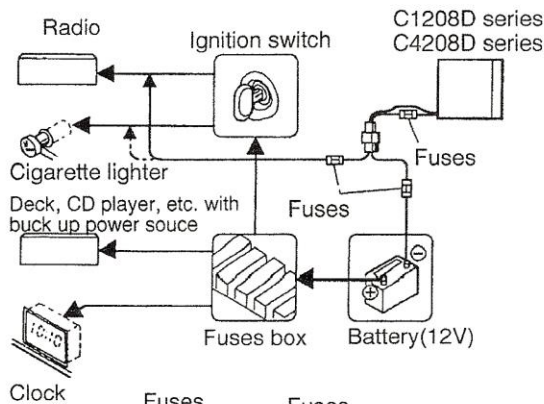
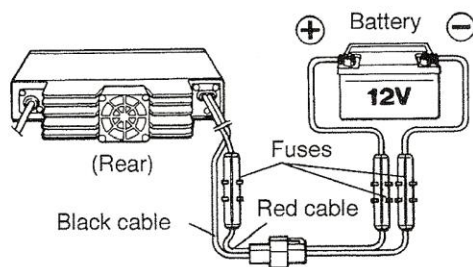
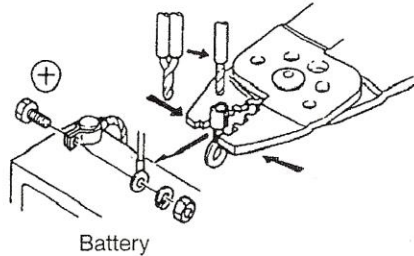

1 Before connection, disconnect the (-) terminal of the battery.
This will prevent a short circuit .

2 Firmly tighten the battery terminals may not be loosened.

3 After tightening the (+) terminal, tighten the (-) terminal .

4 Connect the power connector on the main unit with the connector on the power supply cable.

The red power supply cord is connected to the 12V (+) terminal after it passes the automobile ignition key switch .

The black cord is connected to the 12V (-) terminal.

◆ When using the transceiver on a vehicle with a 24V electrical system, you must use a DC-DC converter to convert 24V to 12V.

◆ If the automobile is not used for a long period of time, disconnect the power supply cord.

◆ This transceiver requires 12A fuses.

Connecting the Power Supply Cable

In case of Fixed Station

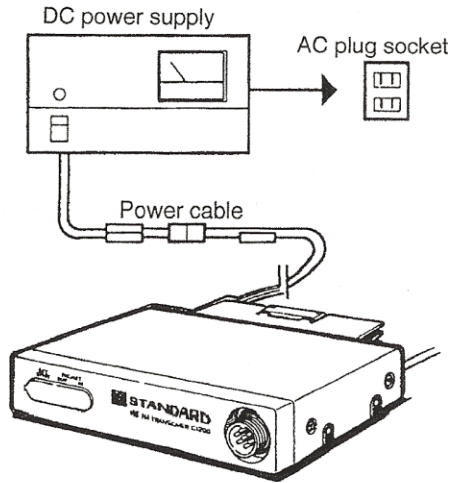

When using the transceiver as a fixed station, use a DC-stabilized power supply, such as the following:

DC Output: 13.8V
Output Current: 12.0A or more

Connecting the Microphone and External Speaker

Connecting the Accessory Microphone

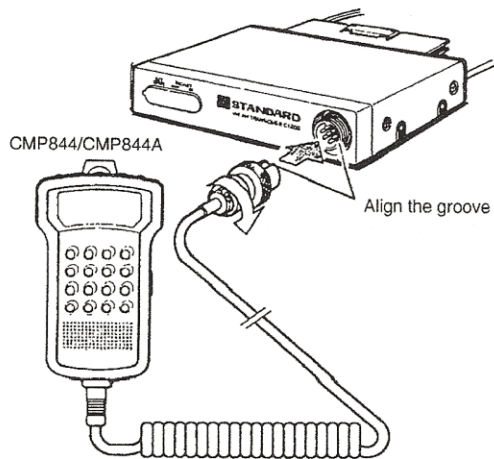

Connecting the Optional External Speaker

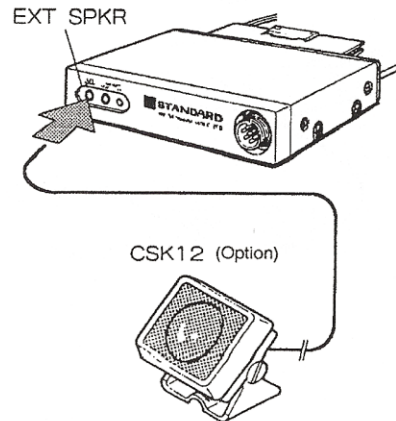

⚠ EXT SPKR is an external speaker only terminal. Do not connect earphones, etc.

Extension Cable

For details, refer to USING THE OPTIONS on Page 64.

Attaching the Antenna

In case of automobile's

Performance of the transceiver depends greatly on antenna characteristics. Select an antenna that matches the operating requirements.

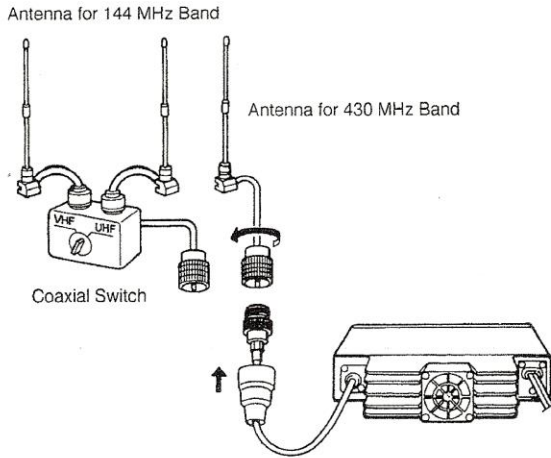

When using a common antenna

- 1 The transceiver has a built-in duplexer. Therefore, a common antenna for 144/430 MHz band can be used.
- 2 Connect the coaxial cable connector on the main unit to an antenna.
Common Antenna for 144/430 MHz Band

When using independent antennas

- 1 Connect the coaxial cable connector on the main unit to a coaxial switch.
- 2 Connect a 144 MHz antenna to the coaxial jack for 144 MHz band on the coaxial switch. Next, connect a 430 MHz antenna to the coaxial jack for 430 MHz band on the coaxial switch.

- ⚠ ◆ Do not scratch or squeeze the coaxial cable.
- ◆ Adjust VSWR of the antenna to 1.5 or less.
- ◆ When mounting an antenna base, connect a ground between the base and the automobile body.

In Case of Fixed Station

When using a vertical antenna, be sure that the antenna itself is not weighted by the coaxial cable.

For fixing a rain protector on the cable, refer to the antenna installation manual.

The following example is for installation on a building. For details, consult with your dealer, our service office, or service center.

For water-proof treatment of connectors, wrap double-sided self-adhesive tape while pulling it for tension, and then wrap single-sided vinyl tape or equivalent on top of it.

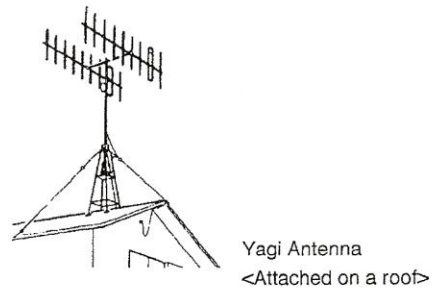
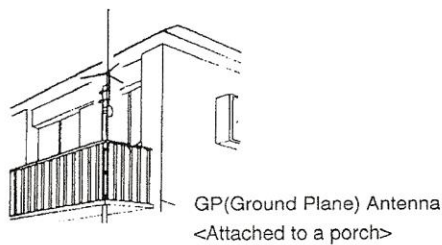

- ⚠ ◆ Check all support lines to be sure that the antenna does not damage surrounding buildings if it falls or is blown down by strong winds.
- ◆ Make the coaxial cable run as short as possible.
- GP (Ground Plane) Antenna <Attached to a porch>
- Yagi Antenna <Attached on a roof>

BASIC OPERATION

CONTROL NAMES AND FUNCTIONS	10
TURNING ON THE POWER	13
ADJUSTING THE VOLUME	13
ADJUSTING THE SQUELCH	14
TURNING OFF THE SQUELCH	14
RECEIVING BAND SELECTION	14
RECEIVING	15
TRANSMITTING	15
List of Function Mode	16
ABOUT BEEP SOUND	17
ABOUT ATTENUATOR	17
List of Set Mode Functions	18

CONTROL NAMES AND FUNCTIONS

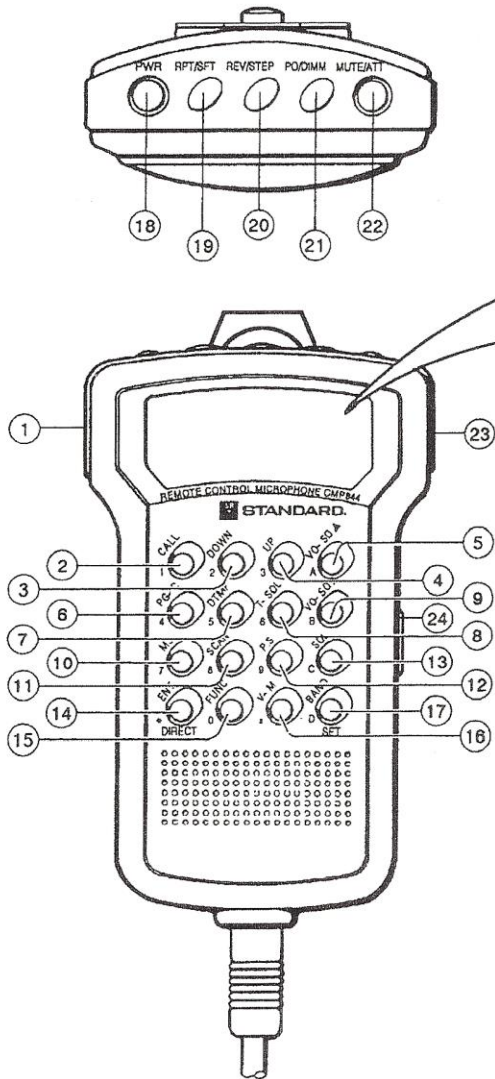

Display

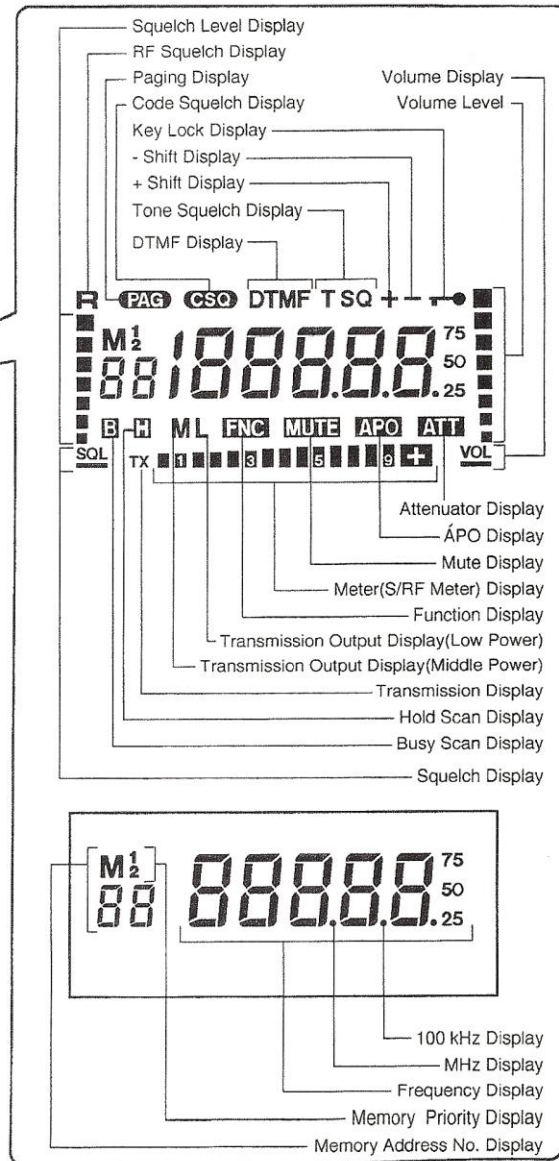

Front and Rear of Main Body

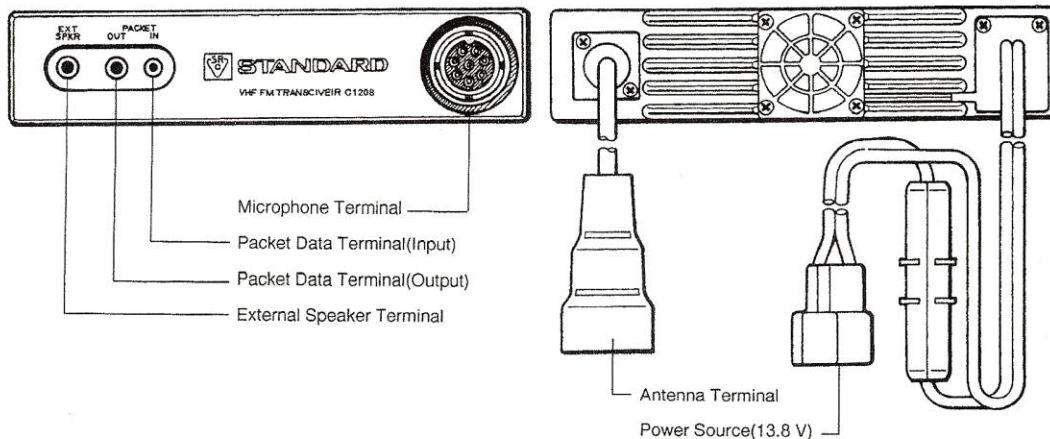

- (1) PTT(C1208D,C1208DS,C4208D,C4208DS)
 - Press this switch to transmit on the Main Band.
- SQL-OFF(C1208DA,C4208DA)
 - Pressing this key turns off the squelch.
 - Pressing this key transmits tone burst while pressing **[PTT]**.
- (2) 1/CALL
 - Press this key to put the Calling Frequency.
 - When pressed in the direct mode, "1" is input.
 - When pressed while pressing **[PTT]**, DTMF signal 1 is output.
- (3) 2/DOWN
 - When this key is pressed, the frequency, memory address number and others are decreased.
 - When pressed in the direct mode, "2" is input.
 - When pressed while pressing **[PTT]**, DTMF signal 2 is output.
- (4) 3/UP
 - When this key is pressed, the frequency, memory address number and others are increased.
 - When pressed in the direct mode, "3" is input.
 - When pressed while pressing **[PTT]**, DTMF signal 3 is output.
- (5) A/VO-SQ ▲
 - When this key is pressed, the volume or squelch level are increased.
 - Press this key when entering a DTMF signal "A".
- When pressed while pressing **[PTT]**, DTMF signal A is output.
- (6) 4/PG-C
 - Pressing this key enables the Paging Mode.
 - When pressed in Paging Mode, code squelch mode is enabled.
 - When pressed in direct mode, "4" is input.
 - When pressed while pressing **[PTT]**, DTMF signal 4 is output.
- (7) 5/DTMF
 - Pressing this key enables the DTMF Mode.
 - When pressed in direct mode, "5" is input.
 - When pressed while pressing **[PTT]**, DTMF signal 5 is output.
- (8) 6/T-SQL
 - Pressing this key enables the Tone Encode Mode. When pressed in tone encode mode, tone squelch mode is enabled.
 - When pressed in direct mode, "6" is input.
 - When pressed while pressing **[PTT]**, DTMF signal 6 is output.
- (9) B/VO-SQ ▼
 - When this key is pressed, the volume or squelch level are decreased.
 - Press this key when entering a DTMF signal "B".
 - When pressed while pressing **[PTT]**, DTMF signal B is output.
- (10) 7/MS
 - Pressing this key scans the frequency stored in the memory.
 - When pressed in direct mode, "7" is input.
 - When pressed while pressing **[PTT]**, DTMF signal 7 is output.

- (11) 8/SCAN
- When this key is pressed, 1 MHz Scan or All-Scan is enabled.
 - When pressed in direct mode, "8" is input.
 - When pressed while pressing **[PTT]**, DTMF signal 8 is output.
- (12) 9/P.S
- Pressing this key enables Program Scan.
 - When pressed in direct mode, "9" is input.
 - When pressed while pressing **[PTT]**, DTMF signal 9 is output.
- (13) C/SQL
- Pressing this key changes volume/squelch adjustment.
 - Press this key when entering a DTMF signal "C".
 - When pressed while pressing **[PTT]**, DTMF signal C is output.
- (14) * /ENT • DIRECT
- Pressing this key allows numbers to be input directly into the transceiver. (P 32).
 - Press this key when entering a DTMF signal "*".
 - When pressed while pressing **[PTT]**, DTMF signal * is output.
- (15) 0/FUNC
- Pressing this key establishes the Function Mode.
In this book, the function mode is indicated by "FNC".
 - When this key is pressed in the direct mode, "0" is input.
 - When this key is pressed while pressing **[PTT]**, DTMF signal 0 is output.
- (16) #/V-M
- Pressing this key causes the transceiver to alternate between VFO mode and operation using frequencies stored in memory.
 - Press this key when entering a DTMF signal "#".
 - When pressed while pressing **[PTT]**, DTMF signal # is output.
- (17) D/BAND • SET
- Pressing this key switches Main Band and Sub-Band.
 - When pressed while pressing **[0/FUNC]**, the Set Mode to be selected.
 - When pressed while pressing **[PTT]**, DTMF signal D is output.
- (18) PWR
- Pressing this key turns on the transceiver.
- (19) RPT/SFT
- Pressing this key enables repeater operation.
 - When pressed while pressing **[0/FUNC]**, the transceiver enters the condition for changing the repeater shift frequency .
- (20) REV/STEP
- Pressing this key reverses the transmit and receive frequencies for repeater operation.
 - When pressed after pressing **[0/FUNC]** key, conditions are set for changing the step frequency.
- (21) PO/DIMM
- Pressing this key changes transmit power.
 - Pressing this key controls display lighting in Function Mode.
- (22) MUTE/ATT
- Pressing this key mutes the audio.
 - Pressing this key sets the RF-ATT in Function Mode.
- (23) SQL-OFF
(C1208D,C1208DS,C4208D,C4208DS)
- Pressing this key turns off the squelch.
 - Pressing this key transmits tone burst while pressing **[PTT]**.
PTT(C1208DA,C4208DA)
 - Press this switch to transmit on the Main Band.
- (24) K-LOCK
- When this key is pushed down, key operations by the CMP844/CMP844A Microphone are disabled.
- [f]** ♦ In order to output the DTMF signal, the optional CTD1200 is necessary.
- ♦ If the optional CTD1200 is not installed, paging, code squelch and DTMF are disabled.
 - ♦ In order to operate the tone squelch, the optional CTN1200 is necessary.
 - ♦ C1208DA and C4208DA are installed the CTD1200 and CTN1200.

TURNING ON THE POWER

- 1 Press the **[PWR]** switch.



- 2 Check the display for indication.

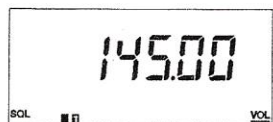

- 3 To turn power off, press the **[PWR]** switch again.



ADJUSTING THE VOLUME

To turn up the volume

Press the **[AVO-SQ▲]** key.

While the key is held down, the volume will increase.

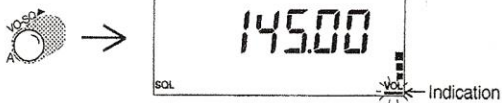

To turn down the volume

Press the **[B/VO-SQ▼]** key.

While the key is held down, volume will decrease.

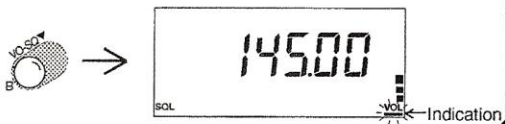

◆ When "-" on under "VOL" on the display is not blinking, press **[SQL]** key.

◆ When adjusting the volume, use the squelch off condition. (P.14)

ADJUSTING THE SQUELCH

Squelch On

When the transceiver is not receiving any signal, it makes a noise like static. The squelch function is used to cancel this noise.

- 1 Press the **[C/SQ]** key.



- 2 Check the display for the "-" indicator on under "SQL".



- 3 Keep pressing the **[AVO-SQ▲]** key. Release the key at the position where the noise disappears.

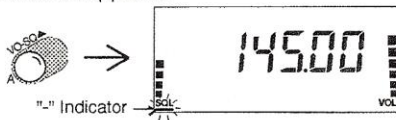

- 4 When the **[BVO-SQ▼]** key is held down, the noise will be heard again.



- ◆ When "-" on under "SQL" on the display is not displaying, press the **[C/SQ]** key.
- ◆ If the squelch level is increased, weak signals may not be received.
- ◆ The condition where noise is heard is called "squelch off". The condition without the noise (squelch operating) is called "squelch on".

TURNING OFF THE SQUELCH

When squelch is on, only signals that exceed the squelch threshold will "open" the squelch and allow audio output. Signals below this threshold will not "open" the squelch circuit and will therefore not be heard. Squelch can be turned off temporarily to check for weak signals or to see if the operating frequency is in use.

- 1 Press the **[SQL OFF]** key to turn squelch off.

C1208D,C1208DS
C4208D,C4208DS



C1208DA,C4208DA



- 2 To turn on the squelch again, press the **[SQL OFF]** key again.

RECEIVING BAND SELECTION

Receiving band can be changed over the band between the Main band and Sub-band.

Receiving ranges be set as follows;

C1208D,C1208DA;	144.000 to 147.995 MHz
C1208DS;	144.000 to 145.995 MHz
C4208D,C4208DS;	430.000 to 439.995 MHz
C4208DA;	420.000 to 449.995 MHz

To select the band

For the C1208D series,

Receiving band is changed over from the 144 MHz band(Main band) to 430 MHz band(Sub-band), and back to 144 MHz band again, every time the **[D/BAND·SET]** key is pressed.

For the C4208D series,

Receiving band is changed over from the 430 MHz band(Main band) to 144 MHz band(Sub-band), and back to 430 MHz band again, every time the **[D/BAND·SET]** key is pressed.

- ◆ The C1208D series refer to the 144 MHz band as the Main band and and C4208D series refer to the 430 MHz band as the main band, respectively, and the other band as the sub-band.

RECEIVING

- 1 Select the band with the **[D/BAND·SET]** key.

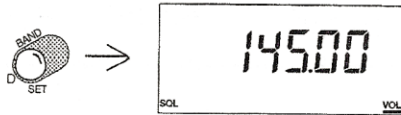

- 2 Verify VFO mode.

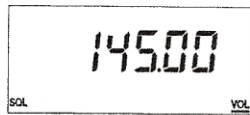

- 3 Press the **[2/DOWN]** or **[3/UP]** key and tune to the desired receive frequency.

The frequency decreases when the **[2/DOWN]** key is pressed.

The frequency increases when the **[3/UP]** key is pressed.

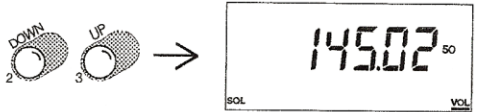

◆ VFO mode is the condition in which the frequency can be changed by the **[2/DOWN]**/**[3/UP]** keys or the keys on the microphone numerical keypad.

◆ Before transmitting, make sure that no one else is transmitting at the same frequency.

TRANSMITTING

You can talk by transmitting between you and the other party you have adjusted

the frequency to. When you press the **[PTT]** switch in the sub-band, transmission is enabled at the main band frequency operated last.

- 1 Select the band with the **[D/BAND·SET]** key.

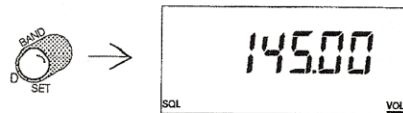

- 2 Verify VFO mode.

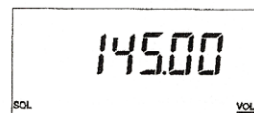

- 3 Press the **[2/DOWN]** or **[3/UP]** key to display the desired transmit frequency .

The frequency decreases when **[2/DOWN]** key is pressed.

The frequency increases when **[3/UP]** key is pressed.

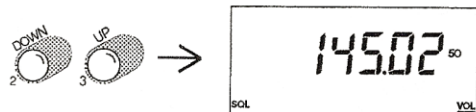

- 4 To transmit, press the microphone **[PTT]** switch and talk into the microphone.

C1208D,C1208DS
C4208D,C4208DS



C1208DA
C4208DA



◆ Before transmitting, be sure that the frequency is not in use.

◆ The frequency can be input on the microphone keypad by 1 MHz or 100 MHz (direct input; 21).

List of Function Mode

To effect the function mode, press the **[0/FUNC]** key and press a relevant key.

Pressing the **[0/FUNC]** key displays "FNC" on the display. When "FNC" is displayed and no key is pressed, it will disappear in about 3 seconds.(You are returned to the VFO mode)

Key Operation	Ref. Page	Function
[0/FUNC] > [2/DOWN]	P 20	The frequency goes down in a step of 1 MHz.
[0/FUNC] > [3/UP]	P 20	The frequency goes up in a step of 1 MHz.
[0/FUNC] > [4/PG-C]	P 54, 55	Sets a paging code or code squelch code.
[0/FUNC] > [5/DTMF]	P 60, 61	Sets a DTMF code.
[0/FUNC] > [6/T-SQL]	P 53	Sets a tone frequency.
[0/FUNC] > [7/MS]	P 38, 39	Sets a scanning priority or block number.
[0/FUNC] > [8/SCAN]	P 36	Selects 1 MHz scan/all scan.
[0/FUNC] > [9/P.S]	P 37	Sets a program scan address
[0/FUNC] > [RPT/SFT]	P 45	Sets a frequency shift.
[0/FUNC] > [REV/STEP]	P 20	Sets a frequency step.
[0/FUNC] > [PO/DIMM]	P 49	Brighten/dim the display.
[0/FUNC] > [MUTE/ATT]	P 17	Turns on/off the attenuator.

ABOUT BEEP SOUND

With a beep sound, you can confirm if each setting has been made correctly.

The beep sound has 3 adjustable stages of magnitude; high, middle, and low.

It can be also turned off. (P. 50)

The beep sound is classified as follows, depending on operations:

- ◆ Short beep When an effective key is operated properly.
- ◆ Long beep When an effective key is operated properly and completed.
- ◆ Buzzing sound When the key is not operated properly or key operation is invalid.
- ◆ Short continuous beep When a signal is received in the Paging mode. A sounding frequency can be changed. (P. 57)
- ◆ Puffing sound When each mode is cleared or the transceiver is reverted to the initial setting.

ABOUT ATTENUATOR

This function attenuates receiving sensitivity upon reception by approx. 8 dB.

It is effective if you use it in the strong electric field or when there are too many external jammings.

The attenuator can be set for each band.

- 1 Press the **[D/BAND·SET]** key to select the band for which you want to set the attenuator.



- 2 Press the **[0/FUNC]** key and press the **[MUTE/ATT]** key.

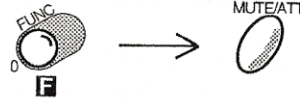

- 3 Make sure that "ATT" appears on the display.



- ◆ To turn off the attenuator (clear the setting), take the above step 2 to turn off a display of "ATT."

List of Set Mode Functions

◆ The Set mode is canceled automatically if you transmit a signal or operate nothing for about 1 minute in the Set mode.

Set Mode No.	Function	Initial Display	Set Mode No.	Function	Initial Display
01	Sets the beep (P 50)	01 bP 2	10	Sets the voice mute level (P 49)	10 MUTE 2
02	Selects the scanning method (P 40)	02 Scn P	11	Sets automatic stop of transmission (P 48)	11 tx 0F
03	Sets the busy scan wait time (P 40)	03 HOL 1	12	Sets the auto power-off time (P 26)	12 0F APG
04	Direct input from the keyboard (P 21)	04 InP 6	13	Sets the time required for a paging signal to be output (P 56)	PAG 13 dY 25
05	Enables the 1MHz step operation (P 20)	05 Ud on ENG	14	Sets the alarm sounding times when a paging signal arrived (P 57)	PAG 14 ALA 7
06	PTT lock (P 48)	06 PL 0F	15	Sets the DTMF code sending speed (P 62)	DTMF 15 Sd 5
07	Enables volume/squelch control in the key locked state (P 23)	07 on SOL VOL	16	Single-tone operation of the DTMF signal (P 63)	DTMF 16 S, 0F
08	Disables modification of the memory (memory protect) (P 30)	M 08 Pr 0F	17	Set the AM Mode operation (P 50)	17 RR on
09	Sets the RF squelch level (P 24)	09 rF 0F			

ADVANCED OPERATION

CHANGING THE FREQUENCY STEP	20
CHANGING THE FREQUENCY STEP TO 1 MHz	20
INPUTTING A FREQUENCY DIRECTLY: SET 04	21
CHANGING THE CALLING FREQUENCY	22
STORING ASSOCIATED DATA WITH THE CALLING FREQUENCY	22
USING THE KEY LOCK	23
DISABLING VOLUME/SQUELCH WHILE IN KEY LOCK: SET 07	23
CONTROLLING THE SQUELCH WITH RF LEVEL: SET 09	24
CHANGING THE TRANSMIT POWER	25
TURNING OFF THE POWER AUTOMATICALLY: SET12	26
RECEIVING IN THE SUB-BAND AND TRANSMITTING IN THE MAIN BAND	26



CHANGING THE FREQUENCY STEP

With the initial setting, frequency will change by 25 kHz steps when the [2/DOWN] or [3/UP] key is pressed.

The amount of this step can be set to 5/10/12.5/15/20/25/50/100 kHz.

This step can be set different steps for each band.

1 Select the band with the [D/BAND-SET] key.

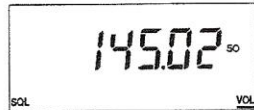

2 Verify VFO mode.

Press the [0/FUNC] key.

Press the [REV/STEP] key.



3 Check the display for the frequency step indication.

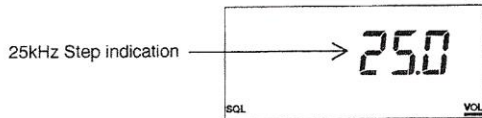

4 Press the [2/DOWN] or [3/UP] key to display the desired frequency step.

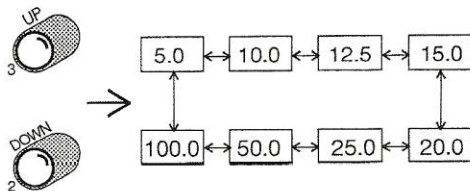

5 To return to VFO mode, press the [0/FUNC] key and then the [REV/STEP] key.

CHANGING THE FREQUENCY STEP TO 1 MHz

The frequency step can be changed to 1 MHz.

1 Set to VFO.

Press the [0/FUNC] key and press the [2/DOWN] or [3/UP] key.

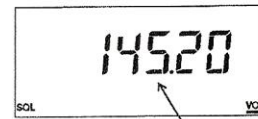

Changing

◆ A frequency change in the step of 1 MHz can be prohibited by changing a display of "on" to "OF" in the Set mode 05.

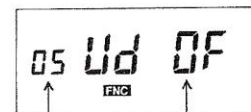

Prohibition of 1 MHz step operation

Display of Set mode 05



INPUTTING A FREQUENCY DIRECTLY

The frequency can be input directly from the numerical keys(0-9).

There are three ways of directly inputting the frequency; inputting from the 1 MHz digit(3-digit input) and 100 MHz digit(5 or 6-digit input). The 5-digit input is convenient when changing the band. The 6-digit input allows you to input down to the 1 kHz digit. In the initial setting(setting upon shipment from the factory), it has been set in 6 digits.

To input from the 100 MHz digit down to 1 kHz digit(6-digit input)

1 Set to VFO.
Select the band with the **[D/BAND-SET]** key.

2 Press the **[*/ENT-DIRECT]** key.

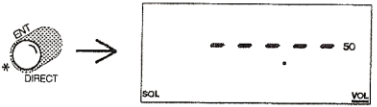

3 Press the key of the number to be input.
Upon inputting the last one digit, a long beep sound is heard (completion of inputting the frequency).

To input from the 100 MHz digit down to 10kHz digit (5-digit input)

1 Set to VFO.
Hold down the **[0/FUNC]** key and press the **[D/BAND-SET]** key.

2 Press the **[2/DOWN]** or **[3/UP]** key to display Set Mode 04.

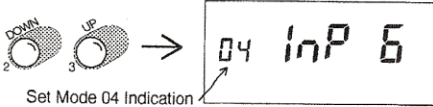

Set Mode 04 Indication

3 Press the **[#/V-M]** key to change the display indication from "6" to "5".

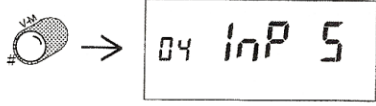

4 Hold down the **[0/FUNC]** key and press the **[D/BAND-SET]** key.
Verify VFO mode.

5 Press the **[*/ENT-DIRECT]** key.

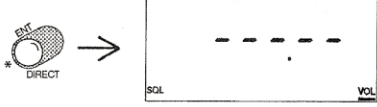

Press the key of the number to be input.
Upon inputting the last one digit, a long beep sound is heard(completion of inputting the frequency).

To input from the 1MHz digit down to 10 kHz digit(3-digit input)

1 Set to VFO.
Hold down the **[0/FUNC]** key and press the **[D/BAND-SET]** key.

2 Press the **[2/DOWN]** or **[3/UP]** key to display Set Mode 04.

3 Press the **[#/V-M]** key to change the display indication from "6" to "3".

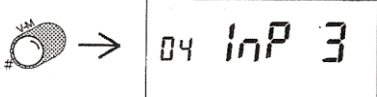

4 Hold down the **[0/FUNC]** key and press the **[D/BAND-SET]** key.
Verify VFO mode.

5 Press the **[*/ENT-DIRECT]** key.

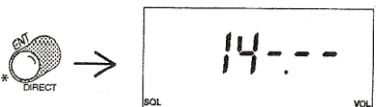

Press the key of the number to be input.
Upon inputting the last one digit, a long beep sound is heard(completion of inputting the frequency).

CHANGING THE CALLING FREQUENCY

The calling frequency can be easily changed in the main-band.

The call frequency of each model (factory setting) is as follows:

C1208D;146.00MHz C4208D;433.00MHz

C1208DS;145.00MHz C4208DS;433.00MHz

C1208DA;146.52MHz C4208DA;446.00MHz

1 Set to the VFO .

2 Press the **[1/CALL]** key.

Check the display for a "C" next to the calling frequency.

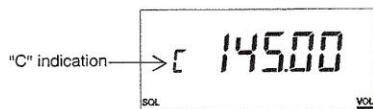

3 Press the **[*/ENT-DIRECT]** key.

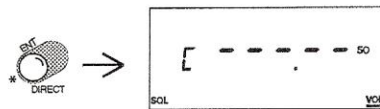

4 Press the key(s) on the keypad to directly input the new calling frequency.

(Rewriting automatically completes when the last digit is input.)



5 To return to VFO, press the **[1/CALL]** key.

If you press the **[2/DOWN]** or **[3/UP]** key when the call frequency is being displayed, you will be returned to the VFO mode, incrementing or decrementing the call frequency by the set frequency step.

Storing Associated Data with the Calling Frequency

Various settings can be stored with the call frequency. These include tones for repeater, paging, code squelch, tone squelch, tone encoder and DTMF.

1 Set to VFO .

2 Press the **[1/CALL]** key.

Check the display for the "C" indication for the call frequency.

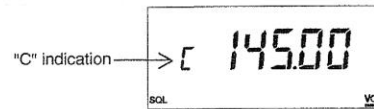

3 Press the appropriate key to associate its function with the frequency at this memory location: [TSQ], [RPT], [PG-C], [DTMF].



4 To return to VFO, press the **[1/CALL]** key.



To cancel each mode, display it press the key once or twice, which you pressed to set the mode. (A puffing sound is heard and the mode is canceled)
A display of each mode disappears.

USING THE KEY LOCK

Key operation can be disabled (except the **PTT**, **SQL OFF**, **A/VO-SQ▲**, **B/VO-SQ▼**, **C/SQL**, and **PWR** keys). This will prevent mistakes in key pressing that could change operation. This operation is called "key lock".

- 1 To enable key lock, slide the **K-LOCK** switch ON.



- 2 Check the display for the key symbol.



- 3 To cancel key lock, slide the **K-LOCK** switch OFF.

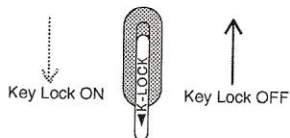

DISABLING VOLUME/SQUELCH WHILE IN KEY LOCK

While in key lock, this function disables the **A/VO-SQ▲**, **B/VO-SQ▼**, and **C/SQL** keys (volume and squelch control).

- 1 Set to VFO. Hold down the **0/FUNC** key and press the **D/BAND-SET** key.



- 2 Press the **2/DOWN** key or **3/UP** key to display Set mode 07.

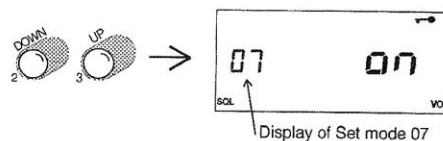

- 3 Press the **#/V-M** key to change the display indication "on" to "OF."

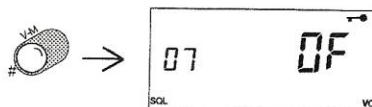

- 4 To return to VFO, hold down the **0/FUNC** key and press the **D/BAND-SET** key.

♦ To cancel this setting, change a display indication from "OF" to "on" in the step 3.



CONTROLLING THE SQUELCH WITH RF LEVEL

There are two ways of setting the squelch threshold. The first (already described) is to set it based on noise from the speaker. The second is to set it to a point equivalent to an S-Meter indication. This second method allows much higher thresholds that can block stronger signals, and is called RF Squelch in this book.

- 1 Set to VFO.
Hold down the **[0/FUNC]** key and press the **[D/BAND-SET]** key.



- 4 To return to VFO, hold down the **[0/FUNC]** key and press the **[D/BAND-SET]** key.



- 2 Press the **[2/DOWN]** or **[3/UP]** key to display Set Mode 09.

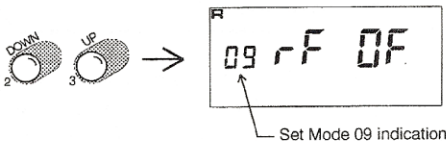

- 5 Press the **[C/SQL]** key to allow adjustment of the squelch level.

Keep pressing the **[A/VO-SQ▲]** key until "R" has been displayed in the display. (This effects the RF squelch at the level you have set in the step 3.)

- 3 Press the **[#/V-M]** key and toggle the display indication from "OF" to the desired value.
Pressing the **[#/V-M]** key repeatedly will toggle the display between "OF (off)", "3", "5", and "F (full)". The numbers 3 and 5 correspond approximately to S-3 and S-5 on an S-meter. "F" corresponds to maximum threshold level, sometimes called "tight squelch".

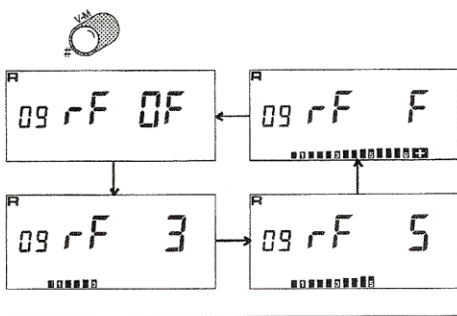

- ◆ When the RF squelch has been set, a scan does not stop unless a signal received during the scan exceeds the set RF level.
- ◆ To cancel the RF squelch, turn off a display of "R" by adjusting the squelch or set "OF" in the step 3.
- ◆ The RF(Radio Frequency) level refers to the strength of a received signal.

CHANGING THE TRANSMIT POWER

Transmit power can be set to one of three levels. The initial setting (as shipped from the factory) is high power.

	High	Medium	Low
C1208D series	50W	10W	3W
C4208D series	40W	10W	3W

- 1 Press the **[PO/DIMM]** key.
Check the display for an "M" indication. (Medium power is set.)

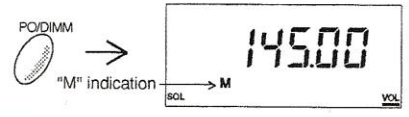

- The display for transmitting with high power:



- The display for transmitting with medium power:



- 2 Press the **[PO/DIMM]** key.
Check the display to verify that the indication changes from "M" to "L". (Low power is set.)

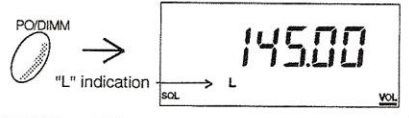

- The display for transmitting with low power:



- 3 Press the **[PO/DIMM]** key.
Check that the "L" indication disappears from the display. (High power is set.)

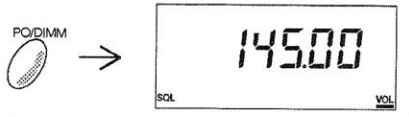

TURNING OFF THE POWER AUTOMATICALLY

The power goes off automatically if no transmission or key operation is done.

This function effectively prevents battery drain when the unit's power supply is being drawn directly from a car battery.

- 1 Set to VFO .
Hold down the **[0/FUNC]** key and press the **[D/BAND-SET]** key.



- 2 Press the **[2/DOWN]** or **[3/UP]** key to display Set Mode 12.

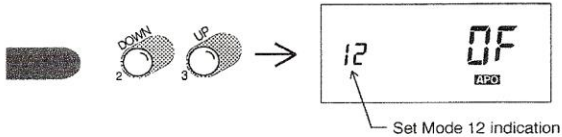

- 3 Press the **[#/V-M]** key and toggle the display indication from "OF" to the desired value.
Pressing the **[#/V-M]** key repeatedly will toggle the display between "OF (off)", "3", "6" and "9".

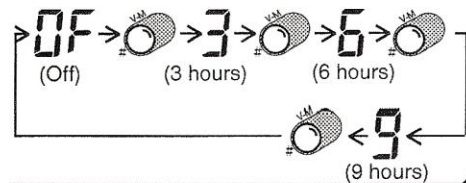

- 4 To return to VFO, hold down the **[0/FUNC]** key and press the **[D/BAND-SET]** key.
Check that the "APO" indication

RECEIVING IN THE SUB-BAND AND TRANSMITTING IN THE MAIN BAND

Transmission and reception can be activated in the different bands.

- 1 Set to main-band, press the **[D/BAND-SET]** key .



- 2 Set to the desired transmit frequency .

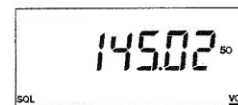

- 3 Set to sub-band, press the **[D/BAND-SET]** key .

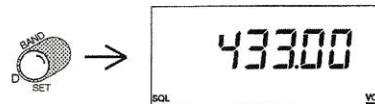

- 4 Set to the desired receive frequency .



- 5 Pressing **[PTT]** enables transmission in the main-band and releasing it enables reception in the sub-band.

MEMORY FUNCTIONS

ABOUT MEMORY	28
STORING OFTEN-USED FREQUENCIES IN MEMORY	29
RECALLING A FREQUENCY FROM MEMORY	29
CHANGING AN OPERATING FREQUENCY IN MEMORY	30
INHIBITING MEMORY MODIFICATION: SET08	30
ERASING DATA AT A SPECIFIC MEMORY ADDRESS	31
ASSIGNING PRIORITY TO MEMORY ADDRESSES	31
ASSIGNING EACH MODE TO MEMORY ADDRESSES	32
COPYING THE MEMORY FREQUENCY TO VFO	32

ABOUT MEMORY

The transceiver has 100 channels of memory. In addition, operating functions can be associated with each stored frequency, such as repeater mode, paging mode, tone frequencies, offset frequency, and scan method. For scanning, memory addresses can be prioritized.

Memory can be protected against accidental erasure or change.

The following items can be stored in memory and associated with the operating frequency at that memory address:

- ◇ Repeater mode **P** 43
- ◇ Tone encode mode **P** 52
- ◇ Tone squelch mode **P** 53
- ◇ Paging mode **P** 56
- ◇ Code squelch mode **P** 57
- ◇ DTMF mode **P** 59

 ♦ For the tone frequency and the shift frequency, different frequencies can be written at each memory address.

STORING OFTEN-USED FREQUENCIES IN MEMORY

Frequencies which are used often can be stored in memory.

1 Set to VFO .

Press the **[2/DOWN]** or **[3/UP]** key to display a frequency to be stored in memory.

2 Press the **[#V-M]** key.

Press the **[2/DOWN]** or **[3/UP]** key to select a memory address with a blinking "M" (this indicates an available memory address) indication blinks.

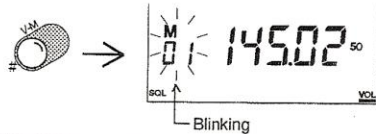

3 Press the **[*/ENT-DIRECT]** key twice.

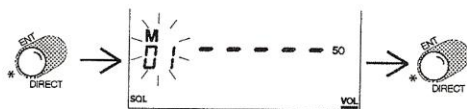

4 Check the display for an unblinking "M" indication.

(The frequency has been placed in memory)

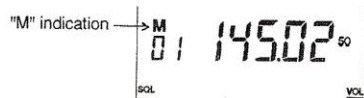

5 Press the **[#V-M]** key.

Verify VFO mode.

- ◆ A blinking "M" means that nothing is stored at this memory address, and that it is available for use.
- ◆ In step 3, To directly input the frequency you want to write, press the **[*/ENT-DIRECT]** key once and press the corresponding numerical keys.
- ◆ Inputting the last one digit generates a beep sound. (This indicates that the frequency has been memorized.)

RECALLING A FREQUENCY FROM MEMORY

A frequency in memory can be recalled after selecting its memory address.

1 Set to VFO .

Press the **[#V-M]** key to set to Memory mode.

2 Press the **[2/DOWN]** or **[3/UP]** key to select the memory address to be recalled. The frequency stored at this address will be displayed and is immediately available for use.

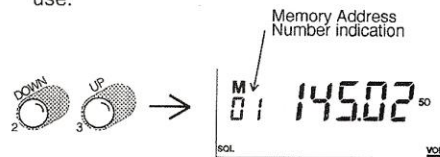

3 Press the **[#V-M]** key to return to VFO mode.

CHANGING AN OPERATING FREQUENCY IN MEMORY

An operating frequency stored in memory can be changed.

- 1 Press the **[#V-M]** key to set to Memory mode.



- 2 Press the **[2/DOWN]** or **[3/UP]** key to select a memory address. The frequency at that address will be displayed.

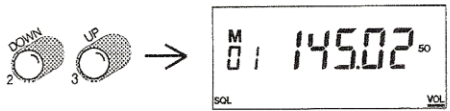

- 3 Press the **[*/ENT-DIRECT]** key.
Check the display for the memory change.

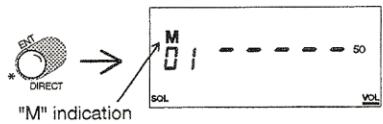

Input the new frequency through the numerical keypad.
A beep sounds when the last digit is input.
(This stores the frequency to memory.)

- 4 Press the **[#V-M]** key.
Verify VFO mode.

In step 3, the up/down functions of the **[2/DOWN]/[3/UP]** keys are disabled. Only the number functions are enabled.

INHIBITING MEMORY MODIFICATION

This function protects data in the memory from being changed or erased by mistake.

- 1 Hold down the **[0/FUNC]** key and press the **[D/BAND-SET]** key.



- 2 Press the **[2/DOWN]** or **[3/UP]** key and display Set Mode 08.

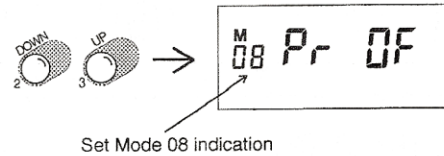

- 3 Press the **[#V-M]** key to change the display from "OF" to "on".

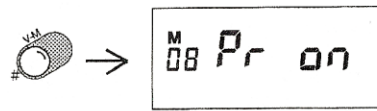

- 4 To return to VFO, hold down the **[0/FUNC]** key and press the **[D/BAND-SET]** key.



Even with memory protect set, memory contents will be erased by All-reset or Memory-Reset operations (P 69).

ERASING DATA AT A SPECIFIC MEMORY ADDRESS

Contents of memory at a specific address can be erased.

- 1 Press the **[#V-M]** key to set to Memory mode.



- 2 Press the **[2/DOWN]** or **[3/UP]** key to select the memory address to be erased.
Memory Address Number indication

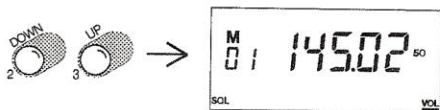

- 3 Press the **[*/ENT-DIRECT]** key.
Check the display for the memory change.

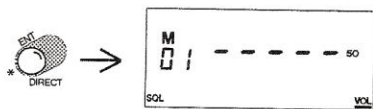

- 4 Press the **[PTT]** on the microphone.

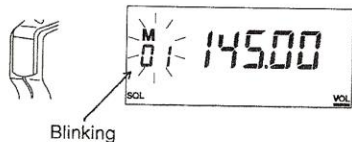

- 5 Press the **[#V-M]** key.
Verify VFO.

ASSIGNING PRIORITY TO MEMORY ADDRESSES

You can assign priorities to memory addresses for use during memory scan.

- 1 Press the **[#V-M]** key to set to Memory mode.



- 2 Press the **[2/DOWN]** or **[3/UP]** key to select the memory address to be assigned a priority.

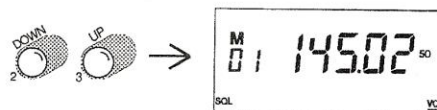

- 3 Press the **[0/FUNC]** key. **F**
Press the **[2/DOWN]** or **[3/UP]** key to select a priority number. **F**
Press the **[0/FUNC]** key. Priority number indication



- 4 Press the **[#V-M]** key.
Verify VFO mode.

- ♦ The priority number changes as the main dial is turned or the **[2/DOWN]** key / **[3/UP]** key is pressed. The order is as follows:
Blank ↔ 1 ↔ 2
- ♦ If priority is set to 1, scan is enabled at scan 1 priority and scan 2 priority.
 - ♦ If priority is set to 2, scan is enabled at scan 2 priority.

ASSIGNING EACH MODE TO MEMORY ADDRESSES

You can assign each mode to memory addresses.

- 1 Press the **[#V-M]** key to set to Memory mode.



- 2 Press the **[2/DOWN]** or **[3/UP]** key to select the memory address number where you set each mode.

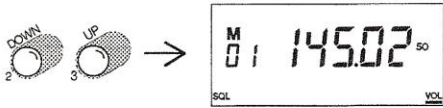

- 3 Press a relevant mode setting key.
For the Tone Squelch or Tone Encode mode;



For the DTMF mode;



For the Paging or Code Squelch mode;



For the Repeater mode;



- 4 Press the **[*ENT-DIRECT]** key twice.



- 5 Press the **[#V-M]** key.
Verify VFO mode.

COPYING THE MEMORY FREQUENCY TO VFO

You can copy the memory frequency to VFO. The frequency can be easily changed by using this function to copy the frequency in the memory to VFO.

- 1 Press the **[#V-M]** key to set to Memory mode.



- 2 Press the **[2/DOWN]** or **[3/UP]** key to select the memory address number.

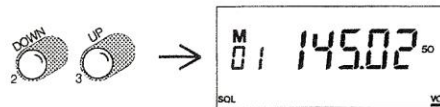

- 3 Hold down the **[0/FUNC]** key and press the **[#V-M]** key.
(This stores the memory frequency to VFO.)



- In this operation, you can copy the memory frequency but the relevant mode, memory tone frequency and offset frequency to VFO.

- In the step 3, to cancel each mode, press the relevant mode setting key. (a display of mode setting is turned off) and press the **[*ENT-DIRECT]** key twice.

- ◆ To change the tone frequency for the Tone Squelch or Tone Encode mode, refer to **P 53**.
- ◆ To change the code for the Paging mode, refer to **P 54 and 55**.
- ◆ To change the code for the Code Squelch mode, refer to **P 55**.
- ◆ To change the shift frequency and tone frequency for the Repeater mode, refer to **P 45**.
- ◆ To change the DTMF code, refer to **P 60**.

SCANNING

ABOUT SCANNING	34
PREPARING FOR SCAN	35
SCANNING WITHIN 1 MHz (1 MHz SCAN)	36
SCANNING THE ENTIRE BANDWIDTH (ALL-SCAN)	36
SCANNING FREQUENCIES IN MEMORY (MEMORY SCAN)	38
SCANNING PRIORITIZED MEMORY (PRIORITY SCAN)	38
SCANNING THE MEMORY BY BLOCK (BLOCK MEMORY SCAN)	39
SCANNING IN TONE SQUELCH MODE	39
SELECTING THE SCANNING METHOD: SET02	40
CHANGING THE WAIT TIME FOR BUSY SCAN: SET 03	40

ABOUT SCANNING

The transceiver has six scanning functions and, within these functions, three scanning methods.

VFO SCAN

- ◇ **1 MHz Scan (P 36)**
Scans without going beyond 1 MHz of the operating frequency.
- ◇ **All-Scan (P 36)**
Scans the entire bandwidth.
- ◇ **Program Scan (P 37)**
Scans a specified range.

MEMORY SCAN

- ◇ **Memory Scan (P 38)**
Scans all frequencies in memory.
- ◇ **Block Memory Scan (P 39)**
Scans the memory by block. A block consists of 10 memory addresses.
- ◇ **Priority Scan (P 38)**
Scans the memory based on previously set priorities.

To stop the scan, the following three methods are available:

- ◇ **Pause Scan (P 40)**
Scan stops when a signal is received, resumes in about 5 seconds even if a signal is still being received.
- ◇ **Busy Scan (P 40)**
Scan stops while a signal is being received, and resumes at a settable time interval after the signal ends: SET03.
The scan can be resumed by pressing the **[2/DOWN]** or **[3/UP]** key, even if the signal is being received.
- ◇ **Hold Scan (P 40)**
Scan stops when a signal is received. The frequency remains unchanged even if the signal is gone. The scan can be resumed by pressing the **[2/DOWN]** or **[3/UP]** key.

 ◆ When scanning in the tone squelch mode, scan speed will slow down to decode a received signal's tone frequency. Scan will stop when the tone frequencies match, and the squelch will open.

PREPARING FOR SCAN

- 1 Set to allow squelch adjustment, press the **[C/SQ]** key.



Check the display for the "—" indicator on under "SQL".



- 2 Press the **[AVO-SQ]** key until noise disappears
Display "—" indication

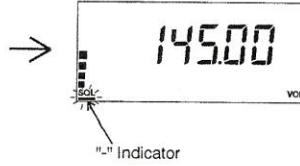

- ◆ Scan will not start while squelch is open (noise is heard) or a signal is being received.
Check that squelch works and a signal is not being received.
- ◆ When **[PTY]** is pushed during scan, scan mode is cancelled and transmission is enabled.
- ◆ To change the scan direction, press the **[2/DOWN]** or **[3/UP]** key.
- ◆ If the **[2/DOWN]** or **[3/UP]** key is pressed while a signal is received and the scan stops, scan will resume at the next frequency to be scanned.
- ◆ If an RF squelch setting has been made, scanning does not stop when a signal is received in scan mode unless the signal level is equal to or greater than the RF squelch level setting.

Typical Scanning

<Example>

When 1 MHz scan is performed with 144.30 MHz displayed

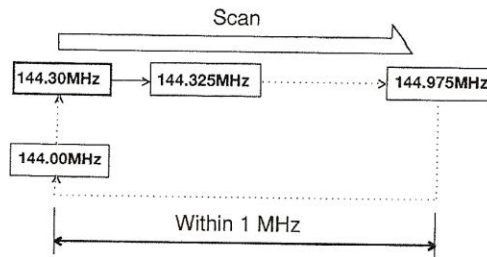

SCANNING WITHIN 1 MHz (1 MHz SCAN)

Scan is done without going beyond 1 MHz of the operating frequency.

- 1 Press the **[2/DOWN]** or **[3/UP]** key to set the scan start frequency.

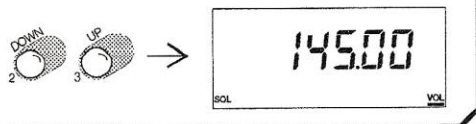

- 2 Press the **[8/SCAN]** key.
Verify that the display is scanning.

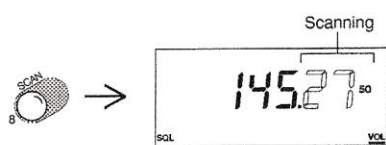

- 3 To stop scanning, press **[8/SCAN]** key.



SCANNING THE ENTIRE BANDWIDTH (ALL-SCAN)

The entire UHF or VHF bandwidth can be scanned.
Memory is not scanned.

- 1 Select the band with the **[D/BAND-SET]** key.
Press the **[2/DOWN]** or **[3/UP]** key to set the scan start frequency.



- 2 Press the **[8/SCAN]** key. This will start a 1 MHz scan.



- 3 Press the **[0/FUNC]** key during 1MHz scan, and then, press the **[8/SCAN]** key. (A short beep will be heard and ALL-Scan has been set.)

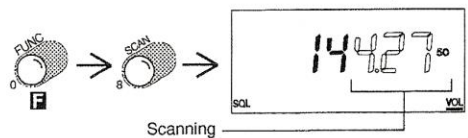

- 4 To stop scanning, press the **[8/SCAN]** key.



- ◆ Once All-Scan is set, it is not necessary to repeat this procedure to initiate it again. Instead, simply press the **[8/SCAN]** key.
- ◆ To change All-Scan to 1 MHz Scan, do steps 3 during All-Scan. A puffing sound will be heard when the change is made.

SCANNING A SPECIFIED RANGE (PROGRAM SCAN)

Memorize a scan start frequency and stop frequency in the memory for the program scan. That range is scanned. This transceiver is provided with 4 sets of memories for the program scan. The following frequencies have been stored in them in advance.

	Start frequency	Stop frequency
C1208D	144.000 MHz	147.975 MHz
C1208DS	144.000 MHz	145.975 MHz
C1208DA	144.000 MHz	147.975 MHz
C4208D	430.000 MHz	439.975 MHz
C4208DS	430.000 MHz	439.975 MHz
C4208DA	420.000 MHz	449.975 MHz

To scan;

- 1 Press the [0/FUNC] key and press the [9/P.S] key.

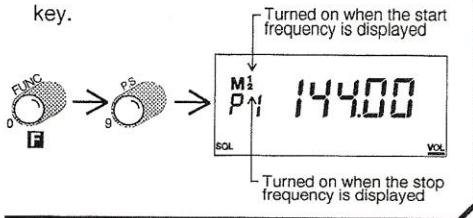

- 2 To call the memory for the scanning range, press the [2/DOWN] or [3/UP] key.

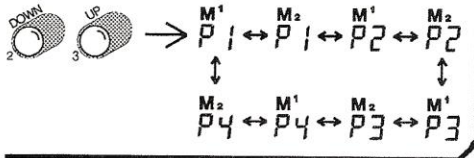

- 3 Press the [9/P.S] key to make sure that scanning is under way.

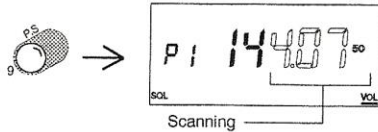

To stop the scan, press the [9/P.S] key again.

- ◆ With this memory, neither transmission nor reception is possible. This memory is only available for setting the frequency. It is also impossible to erase the frequency or set other items than the frequency (paging, tone squelch, etc.).

To modify the memory for the program scan;

- 1 Press the [0/FUNC] key and press the [9/P.S] key.

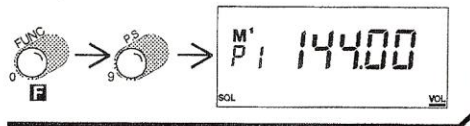

- 2 To call the memory you want to modify, press the [2/DOWN] or [3/UP] key.

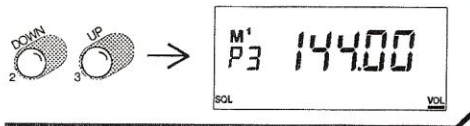

- 3 Input directly the frequency you want to modify.

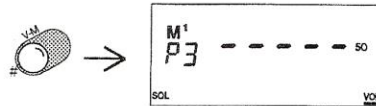

To scan, press the [9/P.S] key.

- ◆ If the start frequency is set in the band different from that of the stop frequency, the stop frequency will be also automatically allowed for direct input. The stop frequency is set in the same manner.
- ◆ If the start frequency is higher than the stop frequency, scanning will not be done between the two. Instead, all in-band frequencies except those between the start and stop frequencies will be scanned.

SCANNING FREQUENCIES IN MEMORY (MEMORY SCAN)

Memory Scan scans all frequencies stored in memory.

- 1 Press the **[7/MS]** key.



- 2 Verify that the display is scanning.

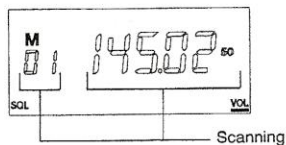

- 3 To stop scanning, press the **[7/MS]** key.



- ◆ Remember that scan will not stop on a signal whose level does not exceed the squelch threshold.
- ◆ The memory scan cannot be done when no frequency has been written in the memory.

SCANNING PRIORITIZED MEMORY (PRIORITY SCAN)

Frequencies at each memory address are scanned in a sequence determined by pre-assigned priorities for each address. Unless the priorities are set to the memories, the priority scan cannot be done. (P 31)

- 1 Press the **[0/FUNC]** key and press the **[7/MS]** key.

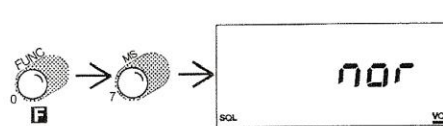

- 2 Press the **[2/DOWN]** or **[3/UP]** key to select scan priority.

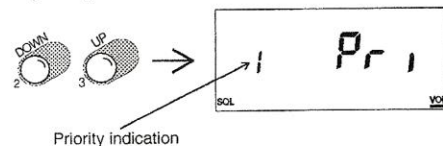

- 3 Press the **[7/MS]** key again and check the display for scanning.

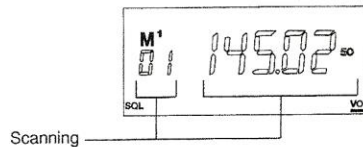

To stop scanning, press **[7/MS]** key.

- ◆ In priority scan 1; memory with priority 1 will be scanned.
- ◆ In priority scan 2, memories with priority 1 and 2 will be scanned.
- ◆ When memory scan without any priority (all memory scan) is done, scan starts after setting a "nor" and start the memory scan.

Scanning the Memory by Block (Block Memory Scan)

The memory is scanned by block. A block is identified by a number from 0 to 9. Each block contains 10 memory addresses. The relation between the block numbers and memory addresses is as follows:

Block Number	Memory Address Number
0	M00 ~ M09
1	M10 ~ M19
2	M20 ~ M29
3	M30 ~ M39
4	M40 ~ M49
5	M50 ~ M59
6	M60 ~ M69
7	M70 ~ M79
8	M80 ~ M89
9	M90 ~ M99

- Press the [0/FUNC] key and press the [7/MS] key. **F**
Press the [2/DOWN] or [3/UP] key to select a block to scan.

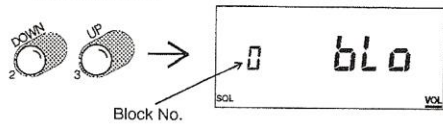

- Press the [7/MS] key.
Verify that the display is scanning.

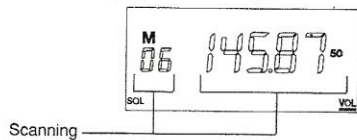

To stop scanning, press [7/MS] key.

- ◆ Block Scan will not work if a block is selected that has no frequencies stored in any of its memory addresses.
- ◆ When you do not want the block memory scan, select "nor" in the step 1. (The memory scan is set.)

SCANNING IN TONE SQUELCH MODE

Scan is done in the tone squelch mode. Scan speed slows down when a signal is received (in order to decode the tone), and scanning stops when the tone frequencies match.

- Press the [6/T-SQL] key twice.
Check the display for the "TSQ" indication and the frequency.



- Press the [8/SCAN] key.
Verify that the display is scanning.

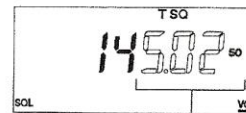

To stop scanning, press the [8/SCAN] key.

- ◆ The program scan also allows scanning in the Tone Squelch mode. In this case, press the [8/P.S] key in the step 2.
- ◆ For the C1208D, C1208DS, C4208D, C4208DS, the optional GTN1200 Tone Squelch Unit must be installed in the transceiver in order to scan in the tone squelch mode.

SELECTING THE SCANNING METHOD

There are three scan methods. In Pause Scan, scan stops when a signal is received, resumes in about 5 seconds even if a signal is still being received. In Busy Scan, scan stops while a signal is being received, and resumes at a settable time interval after the signal ends. In Hold Scan, scan stops when a signal is received. The scan can be resumed by pressing the **2/DOWN** or **3/UP** key.

- 1 Hold down the **0/FUNC** key and press the **D/BAND·SET** key.
Press the **2/DOWN** or **3/UP** key and display Set Mode 02.

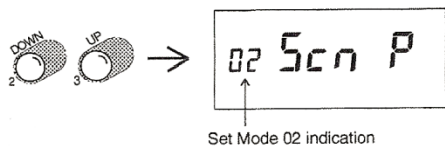

- 2 Press the **#V-M** key and set the scan method.
Every time the **#V-M** key is pressed, the display toggles between "P" (Pause), "b" (Busy) and "H" (Hold).

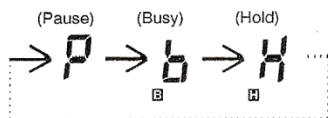

- 3 Hold down the **0/FUNC** key and press the **D/BAND·SET** key.
If Busy Scan is selected, check the display for the "B" indication.
If Hold Scan is selected, check the display for the "H" indication.

- ◆ In the initial condition (as shipped from the factory), Pause Scan is set.
- ◆ The memory scan is also performed in the same scanning method.

CHANGING THE WAIT TIME FOR BUSY SCAN

In Busy Scan, it is possible to set a time from the end of the signal to the resumption of scan.

- 1 Hold down the **0/FUNC** key and press the **D/BAND·SET** key.
Press the **2/DOWN** or **3/UP** key and display Set Mode 03.

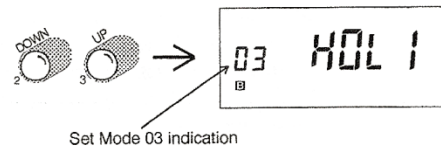

- 2 Press the **#V-M** key to select the hold time.
Every time the **#V-M** key is pressed, the display toggles between "1", "3", "4", and "5".

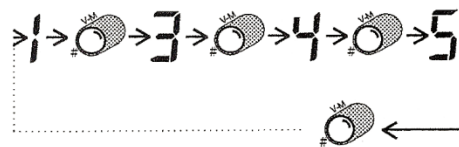

"1" for about 1 second, "3" for about 3 seconds, "4" for about 4 seconds, and "5" for about 5 seconds.

- 3 To return previous mode, Hold down the **0/FUNC** key and press the **D/BAND·SET** key.

- ◆ In the initial condition (as shipped from the factory), hold time is set to "1".

OPERATION AS A REPEATER

GENERAL INFORMATION	42
SETTING THE REPEATER MODE	43
TRANSMITTING A 1750Hz TONE BURST	43
SETTING THE TRANSMIT FREQUENCY HIGERTHAN RECEIVE FREQUENCY	44
REVERSING THE REPEATER TRANSMIT/ RECEIVE FREQUENCIES	44
CHANGING THE REPEATER OFFSET FREQUENCY	45
CHANGING THE REPEATER TONE FREQUENCY	45
SETTING THE SIFT WITHOUT TONE ENCODER	46
SIFTING THE FREQUENCY WITHOUT TONE ENCODER	47

GENERAL INFORMATION

- Communicating by using a repeater station (automatic relay station) is called "repeater operation".
- Communication with a place where signals do not directly reach can be done by using the transceiver as a repeater station.
- In repeater operation, frequencies for transmission and reception are different. This difference is called the "offset frequency".

The offset frequency has been set as follows (when the radio was shipped from factory):

C1208DA; 600kHz C4208DA; 5MHz
C1208D, C1208DS, C4208D, C4208DS; 0.0MHz

- The figure below shows the example where the offset frequency is set 600 kHz in the 144 MHz band.

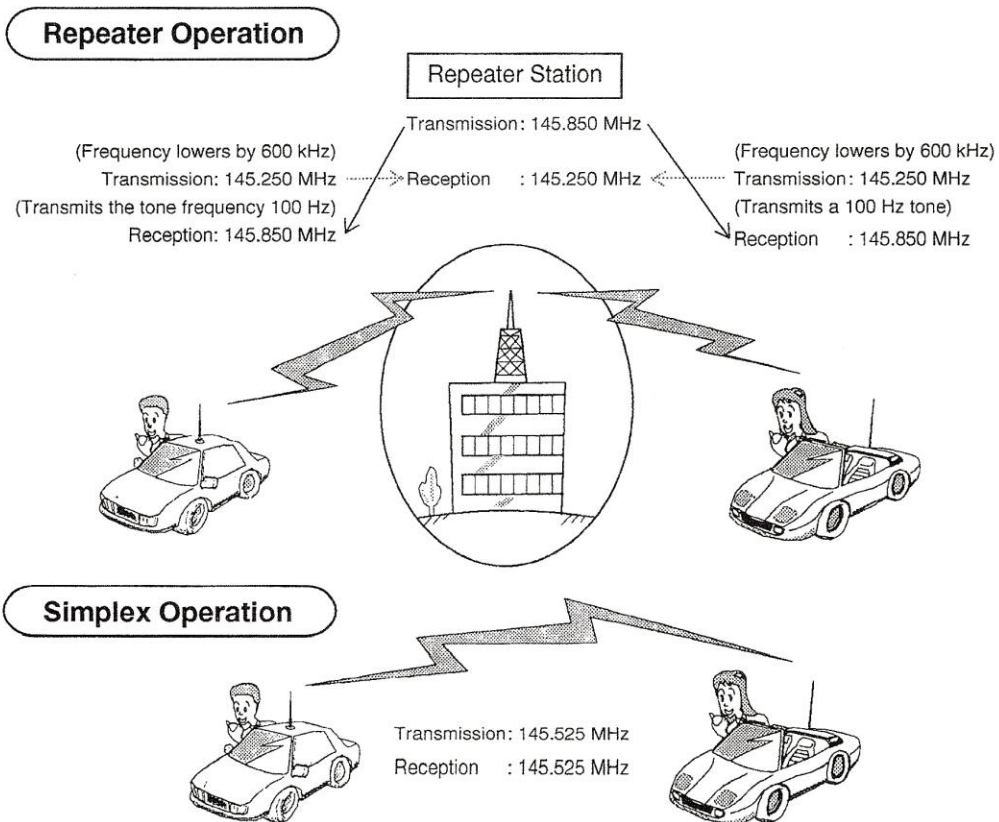

SETTING THE REPEATER MODE

The Repeater Mode can be manually set

1 Press the **[D/BAND-SET]** key and select the main-band.

2 Set to VFO.

3 Press the **[2/DOWN]** or **[3/UP]** key and tune to the frequency for the repeater station.

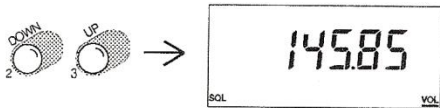

4 Press the **[RPT/SFT]** key.

5 Check the display for the "-" or "T-" indication.

C1208D/DS, C4208D/DS:
"-" indication
C1208DA, C4208DA:
"T-" indication

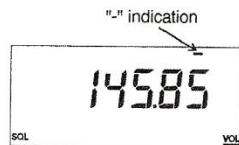

6 To exit the repeater mode, press the **[RPT/SFT]** key twice.



 ♦Transmission cannot be done if the transmit frequency (depend on the offset frequency) is not in the amateur band. In this condition, the display will show "OFF".

TRANSMITTING A 1750 Hz TONE BURST

1 Press the **[D/BAND-SET]** key and select the main-band.

2 Set to Repeater mode, press the **[RPT/SFT]** key.

3 Press the **[2/DOWN]** or **[3/UP]** key to select the repeater station frequency.

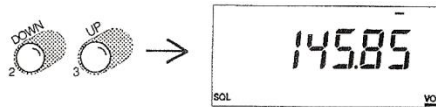

4 Hold down the **[PTT]** and press the **[SQL OFF]** key.

The tone burst is transmitted when the **[SQL OFF]** key is pressed during this procedure.

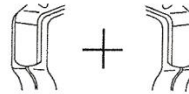

SETTING THE TRANSMIT FREQUENCY HIGHER THAN THE RECEIVE FREQUENCY

In normal repeater mode, the transmit frequency is lower than the receive frequency by 600 kHz. However, this offset can be reversed. Note that this does not change the receive frequency, but only shifts the transmit frequency higher or lower than the receive frequency.

1 Press the **[D/BAND·SET]** key and select the main-band.

2 Set to VFO.

3 Press the **[RPT/SFT]** key twice.

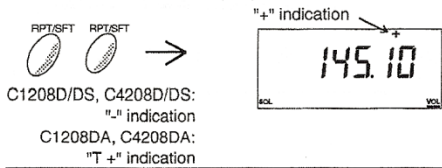

4 To exit the repeater mode, press the **[RPT/SFT]** key.



♦ Transmission cannot be done if the transmit frequency (depend on the offset frequency) is not in the amateur band. In this condition, the display will show "OFF".

REVERSING THE REPEATER TRANSMIT/RECEIVE FREQUENCIES

In normal repeater operation, the transmit frequency is lower than the receive frequency. However, it is possible to reverse these frequencies so that the transmit frequency becomes the receive frequency and vice versa. This function is used when receiving a signal directly (a signal without intervening repeater station) from a partner station. In addition, when direct signals can be received, try communication in simplex mode.

1 Press the **[D/BAND·SET]** key and select the main-band.

2 Set to VFO.

3 Press the **[2/DOWN]** or **[3/UP]** key to display the repeater station frequency.

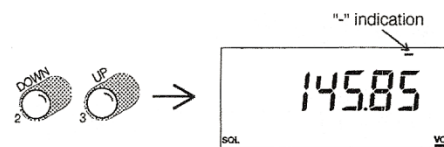

4 Press the **[REV/STEP]** key.

5 The frequency indication on the display lowers by 600 kHz.

Check the display for blinking of the "-" or "+" indication.

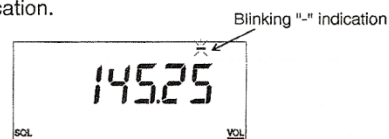

6 To end reversing, press the **[REV/STEP]** key.



♦ In step 3, direct input is possible.

CHANGING THE REPEATER OFFSET FREQUENCY

The offset frequency can be set to a value other than the default value of 0 kHz.

1 Press the **[D/BAND-SET]** key and select the main-band.

2 Set to VFO.

3 Hold down the **[0/FUNC]** key and press the **[RPT/SFT]** key.

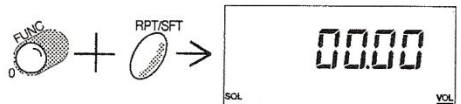

4 Press the **[2/DOWN]** or **[3/UP]** key to set a new offset frequency.



5 To return to VFO, hold down the **[0/FUNC]** key and press the **[RPT/SFT]** key.



♦ To change the memory offset frequency, switch to the memory mode and perform the above steps from 3 onward. To change the call offset frequency, switch to the call mode and perform the above steps from 3 onward. In either of the above cases, the new offset frequency will take effect when step 5 is performed.

- ♦ In step 4, direct input is possible.
- ♦ The initial offset frequency be set as follows; C1208D; 0 MHz, C1208DS; 0 MHz, C1208DA; 600 kHz, C4208D; 0 MHz, C4208DS; 0 MHz, C4208DA; 5MHz

CHANGING THE REPEATER TONE FREQUENCY

The repeater tone frequency can be changed. This function can be activated only the C1208DA/ C4208DA.

1 Press the **[D/BAND-SET]** key and select the main-band.

2 Set to VFO.

3 Press the **[0/FUNC]** key and press the **[6/T-SQL]** key.

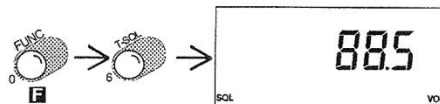

4 Press the **[2/DOWN]** or **[3/UP]** key to select the new tone frequency.



5 Press the **[0/FUNC]** key and press the **[6/T-SQL]** key.



♦ To change the memory tone frequency, switch to the memory mode and perform the above steps from 3 onward. To change the call tone frequency, switch to the call mode and perform the above steps from 3 onward. In either of the above cases, the new tone frequency will take effect when step 5 is performed.

SHIFTING THE FREQUENCY WITHOUT TONE ENCODER

This function can be activated only the C1208DA/C4208DA.

1 Press the **[D/BAND·SET]** key and select the main-band.

2 Set to VFO.

3 Press the **[2/DOWN]** or **[3/UP]** key to set the frequency.

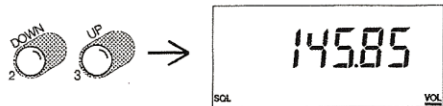

4 Press the **[0/FUNC]** key and press the **[RPT/SFT]** key.

Check the display for the "-" indication.

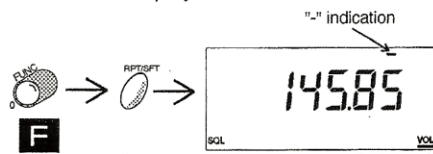

5 To end this function, press the **[0/FUNC]** key and press the **[RPT/SFT]** key twice. **F**

ADDITIONAL FEATURES

PREVENTING UNINTENTIONAL TRANSMISSION (PTT LOCK): SET 06	48
SETTING AUTOMATIC END OF TRANSMISSION (TIME OUT TIMER): SET 11	48
ADJUSTING DISPLAY LIGHTING (DIMMER)	49
REDUCING THE AUDIO OUTPUT (MUTING)	49
CHANGING THE AUDIO MUTING LEVEL: SET 10	49
CHANGING THE BEEP AUDIO VOLUME: SET 01	50
AM MODE OPERATE: SET 17	50

PREVENTING UNINTENTIONAL TRANSMISSION (PTT LOCK)

To prevent unintentional transmission, the PTT can be disabled.

- 1 Hold down the **[0/FUNC]** key and press the **[D/BAND-SET]** key.



- 2 Press the **[2/DOWN]** or **[3/UP]** key to select Set Mode06.

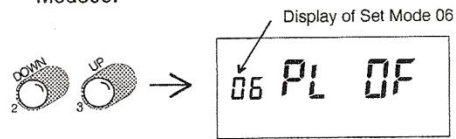

- 3 Press the **[#/V-M]** key to change "OF" on the display block to "on".

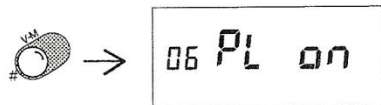

- 4 Hold down the **[0/FUNC]** key and press the **[D/BAND-SET]** key.



- 5 Verify VFO.

- ◆ To cancel this operation, change "on" to "OF" in step 3.
- ◆ In the PTT lock state, pressing **[PTT]** shows "PL" on the display block.

SETTING AUTOMATIC END OF TRANSMISSION (TIME OUT TIMER)

Enabling this feature will stop transmission automatically. When transmission stops, a beep sounds. You can select and set a lead time to stop transmission out of 3 kinds; 3 minutes, 5 minutes, and 15 minutes. This function is not enabled in the initial condition ("OF").

- 1 Hold down the **[0/FUNC]** key and press the **[D/BAND-SET]** key.



- 2 Press the **[2/DOWN]** or **[3/UP]** key to select Set Mode11.

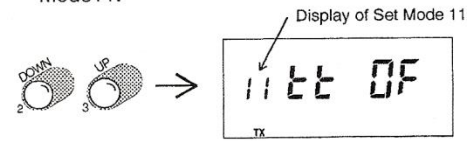

- 3 Press the **[#/V-M]** key to select the time. Every time the **[#/V-M]** key is pressed, the display toggles between "OF", "3", "5", and "15".

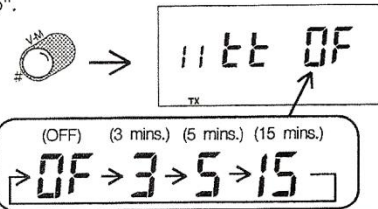

- 4 Hold down the **[0/FUNC]** key and press the **[D/BAND-SET]** key.



- 5 Verify VFO.

- ◆ In order to prevent unintentional transmission from a "mobile microphone", it is recommended that you leave this function turned on.

ADJUSTING DISPLAY LIGHTING (DIMMER)

- 1 Press the **[0/FUNC]** key and press the **[PO/DIMM]** key.

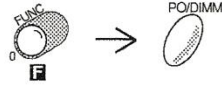

- 2 To return to the original state, repeat step 1.



REDUCING THE AUDIO OUTPUT (MUTING)

Audio output can be reduced to a preset level. This operation is referred to as muting.

- 1 Press the **[MUTE/ATT]** key.



- 2 Confirm that "MUTE" is displayed on display. Also, confirm that audio has been lowered.



- 3 To cancel this operation, press the **[MUTE/ATT]** key.



CHANGING THE AUDIO MUTING LEVEL

The audio muting level can be changed.

- 1 Hold down the **[0/FUNC]** key and press the **[D/BAND·SET]** key.



- 2 Press the **[2/DOWN]** or **[3/UP]** key to select Set Mode10.

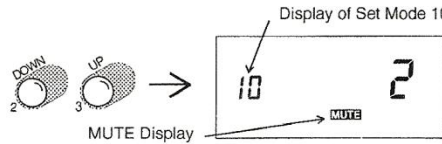

- 3 Press the **[#/V-M]** key to determine the level. Every time the **[#/V-M]** key is pressed, the display toggles in the following order: "2", "3", "F", and "1".
(The initial value is "2". Selecting "3" lower the audio and selecting "1" raises it. Selecting "F" inhibits the audio.)

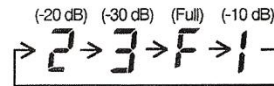

- 4 Hold down the **[0/FUNC]** key and press the **[D/BAND·SET]** key.



- 5 Verify VFO.

CHANGING THE BEEP AUDIO VOLUME

You can change the volume of the beep sound that occurs when an improper operation is attempted.

- 1 Hold down the **[0/FUNC]** key and press the **[D/BAND-SET]** key.



- 2 Press the **[2/DOWN]** or **[3/UP]** key to select Set Mode 01.

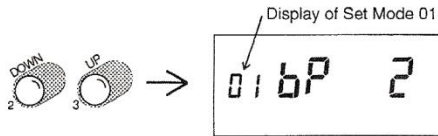

- 3 Press the **[#/V-M]** key to determine the level. Every time the **[#/V-M]** key is pressed, the display toggles in the following order; "2"(Medium), "3"(High), "OF"(Off), and "1"(Low).

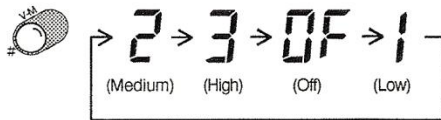

- 4 Hold down the **[0/FUNC]** key and press the **[D/BAND-SET]** key.



- 5 Verify VFO.

AM MODE OPERATE

As received from the factory, the transceiver is set to receive amplitude-modulated (AM) signals in the following frequency range:

118.000 to 142.500 MHz

250.000 to 327.500 MHz

This feature can be turned off so that these range are FM like that other frequencies of the transceiver.

This function can be activated only the C1208DA and C4208DA.

This function can be inhabited as follows;

- 1 Hold down the **[0/FUNC]** key and press the **[D/BAND-SET]** key.

- 2 Press the **[2/DOWN]** or **[3/UP]** key to select Set Mode 17.

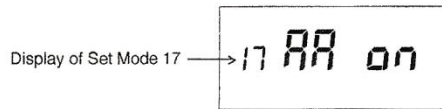

- 3 Press the **[#/V-M]** key to change "on" on the display block to "OF".

- 4 Hold down the **[0/FUNC]** key and press the **[D/BAND-SET]** key.

- 5 Verify VFO.

It is possible to switch temporarily between AM and FM by hold down the **[0/FUNC]** key and press the **[1/CALL]** key.

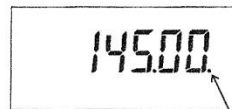

AM mode; display of the dot
FM mode; disappear of the dot

USING OPTIONS

ABOUT THE CTN1200 TONE SQUELCH UNIT	52
USING THE TONE ENCODER	52
USING TONE SQUELCH	53
CHANGING THE TONE FREQUENCY	53
ABOUT THE CTD1200 DTMF UNIT	54
INPUTTING ANOTHER PARTY'S PAGING/ SQUELCH CODE	55
SETTING A GROUP CODE	55
PAGING METHOD	56
CHANGING THE TIME REQUIRED FOR PAGING SIGNAL OUTPUT: SET 13	56
CHANGING THE NUMBER OF PAGING ALERTS: SET 14	57
USING CODE SQUELCH	57
USING THE DTMF	59
ABOUT ATORING AND DISPLAYING THE DTMF CODE	59
STORING THE DTMF CODE	60
SENDING THE STORED DTMF CODE	60
CHANGING THE DTMF CODE IN MEMORY	61
CONFIRMING THE STORED DTMF CODE	61
ERASING THE STORED DTMF CODE	62
CHANGING THE DTMF CODE SENDING SPEED: SET 15	62
CHANGING THE DTMF TO A SINGLE TONE: SET 16	63
USING THE OPTIONAL CABLES (CAW560, CAW561, CAW562, CAW575, CAW576)	64
9,600 bps HIGH-SPEED PACKET OPERATION (G3RUH SYSTEM)	65
1,200 bps PACKET OPERATION	66

ABOUT THE CTN1200 TONE SQUELCH UNIT

The CTN1200 has been attached to the C1208DA and C4208DA already.

As a tone encoder, the CTN1200 unit allows the transceiver to be configured to add (encode) a tone to the carrier when transmitting. Reception is not affected. When permitted by law, this tone encode on the carrier can be used to access certain types of equipment such as a repeater.

As a tone squelch device, the CTN1200 unit generates a tone (sometimes called a code) that is added to the carrier and "looks for" that same tone on received signals. If the generated tone and the received tone match, the transceiver's squelch circuits will open and allow audio output. If the two codes do not match, squelch will not open, and no audio will be output.

• Tone Encoder

A tone signal is output on transmission.
Received signals do not require a tone.

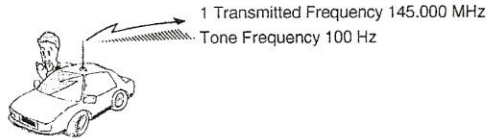

• Tone Squelch

A tone signal is output on transmission. Another transceiver cannot receive the transmission unless its tone squelch code is the same as the one transmitted.

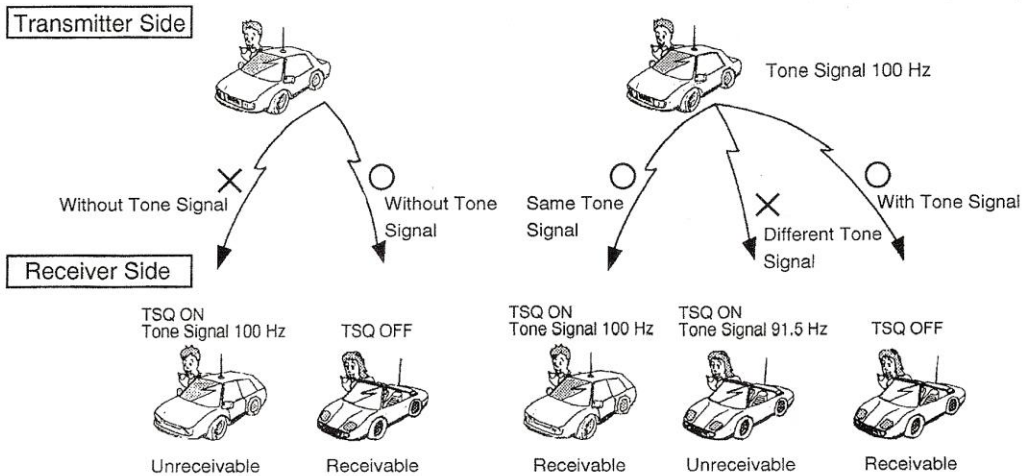

USING THE TONE ENCODER

1 Select the main-band with the **[D/BAND-SET]** key.

2 Set to VFO.

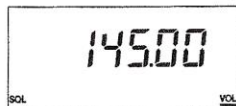

3 Press the **[6/T-SQL]** key.

4 Confirm that "T" is displayed on the display block.

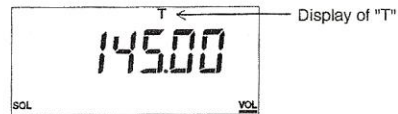

5 On transmission, a tone signal is output.

6 To turn off the tone encoder, press the **[6/T-SQL]** key twice.

USING TONE SQUELCH

- 1 Select the main-band with the **[D/BAND-SET]** key.



- 2 Set to VFO.



- 3 Press the **[6/T-SQL]** key twice.



- 4 Confirm that "TSQ" is displayed on the display block.

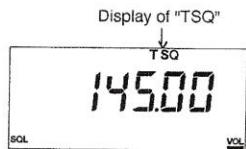

- 5 For reception, audio is output when the tone signals match. On transmission, the tone signal is output.

- 6 To turn off the tone squelch, press the **[6/T-SQL]** key.



- ◆ In the sub-band, the Tone Encode mode (only "T" displayed) cannot be set. The tone squelch is available for reception only.

CHANGING THE TONE FREQUENCY

- 1 Select the main-band with the **[D/BAND-SET]** key.



- 2 Set to VFO.

- 3 Press the **[0/FUNC]** key and press the **[6/T-SQL]** key.

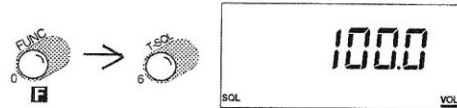

- 4 Press the **[2/DOWN]** or **[3/UP]** key, set the desired tone frequency.

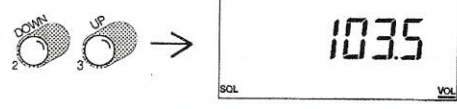

- 5 Press the **[0/FUNC]** key and press the **[6/T-SQL]** key (this provides a new tone signal).

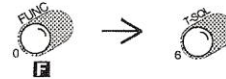

- ◆ To change the memory tone frequency, switch to the memory mode and perform the above steps from 3 onward. To change the call tone frequency, switch to the call mode and perform the above steps from 3 onward. In either of the above cases, the new tone frequency will take effect when step 5 is performed.

- ◆ Initially, the tone frequency has been set to as follows;

C1208D/C1208DS/C4208D/C4208DS; 100.0 Hz

C1208DA/C4208DA; 88.5 Hz

TONE SIGNAL FREQUENCY (Hz)

67.0	85.4	103.5	127.3	156.7	192.8	241.8
71.9	88.5	107.2	131.8	162.2	203.5	250.3
74.4	91.5	110.9	136.5	167.9	210.7	
77.0	94.8	114.8	141.3	173.8	218.1	
79.7	97.4	118.8	146.2	179.9	225.7	
82.5	100.0	123.0	151.4	186.2	233.6	

ABOUT THE CTD1200 DTMF UNIT

The CTD1200 has been attached to the C1208DA and C4208DA already.

The optional DTMF unit allows conventional operation that requires DTMF tones, such as dialing a telephone through a repeater (where this is permitted).

In addition, the DTMF unit allows a paging function where an audio alert signal is produced in the receiving party's transceiver. At the same time, the calling party's 3-digit code appears on the display of the receiving party's transceiver.

And, the DTMF unit allows code squelch operation similar to that performed by the CTN1200 tone squelch.

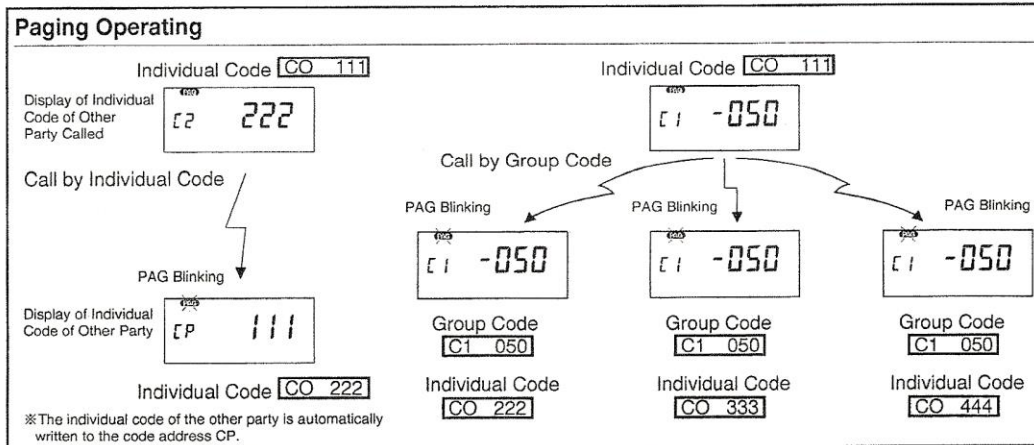

SETTING YOUR OWN INDIVIDUAL CODE

1 Set to VFO.
Press the [0/FUNC] key and press the [4/PG-C] key.

4 Press the numerical key to enter the 1st digit.

2 Press the [2/DOWN] or [3/UP] key to select the memory location (C0) for your own individual code.

5 Press the numerical key to enter the 2nd digit.

3 Press the [*/ENT-DIRECT] key.

6 Press the numerical key to enter the 3rd digit.
(Your own individual code has been set and a long beep will be heard.)

7 To return to VFO, press the [0/FUNC] key and press the [4/PG-C] key.

INPUTTING ANOTHER PARTY'S PAGING/CODE SQUELCH CODE

After you learn the paging/code squelch code of another party, that code can be put in the transceiver.

1 Press the **[0/FUNC]** key and press the **[4/PG-C]** key.



2 Press the **[2/DOWN]** or **[3/UP]** key to select the memory address (C1 to C8) for the individual code of the other party.

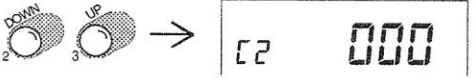

3 Press the **[*/ENT·DIRECT]** key.

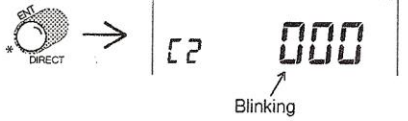

4 Press the numerical key to enter the 1st digit.

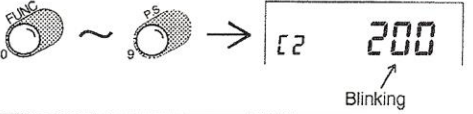

5 Press the numerical key to enter the 2nd digit.

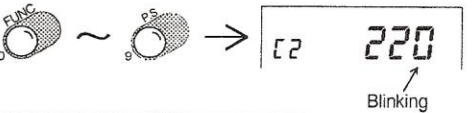

6 Press the numerical key to enter the 3rd digit. (The individual code has been set and a long beep will be heard.)

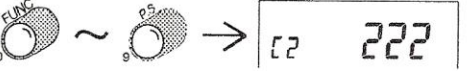

7 To return to VFO, press the **[0/FUNC]** key and press the **[4/PG-C]** key.

SETTING A GROUP CODE

1 Press the **[0/FUNC]** key and press the **[4/PG-C]** key.



2 Press the **[2/DOWN]** or **[3/UP]** key to set the desired group code. (The group code can be set to C1-C8)

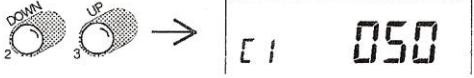

3 Press the **[4/PG-C]** key. (The code is prefixed by "-" and has become the group code)

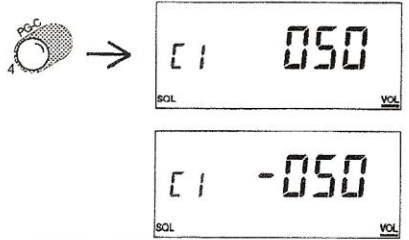

4 To return to VFO, press the **[0/FUNC]** key and press the **[4/PG-C]** key.

◆ To reset the group code, perform the same procedure with the code which has been set as the group code. At this time, confirm that the minus (-) sign prefixing the code has disappeared.

PAGING METHOD

This procedure describes how to set up the paging mode and to receive/answer/initiate paging calls.

1 Set to VFO.

Make sure that the squelch condition is correct (no noise heard from the speaker)

2 Press the [4/PG-C] key. The PAG indicator will be displayed. This is the paging mode.

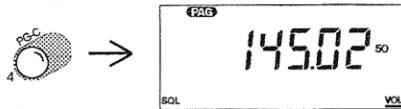

3 When you are paged, "PAG" will blink, an alert will sound, and partner's individual code or group code of the other party will appear on the display.

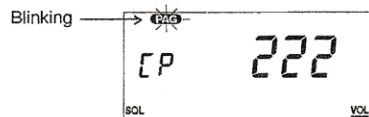

4 Press the [PTT] to respond.

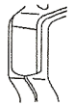

5 When communications are finished, exit the paging mode by pressing the [4/PG-C] twice. This returns the receiver to normal operations.



- ◆ When paging, set the paging function in the step 2, and then, press the [PTT] switch. After receiving a response from the other party, cancel the paging function as described in the step 5.

CHANGING THE TIME REQUIRED FOR PAGING SIGNAL OUTPUT

Normally, the paging signal is output about 250 msec after [PTT] is pressed. This time period can be altered to either 450 msec or 850 msec.

1 Set to VFO.

Hold down the [0/FUNC] key and press the [D/BAND-SET] key.



2 Press the [2/DOWN] or [3/UP] key to select Set Mode 13.

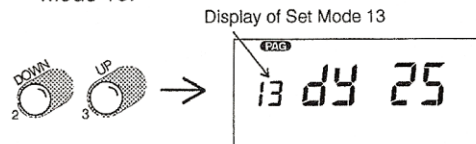

3 Press the [#/V-M] key to change the display from 250 to 450 or 850.

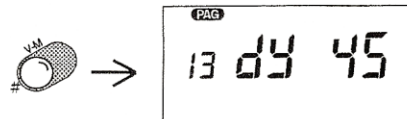

4 After the new time period is selected, hold down the [0/FUNC] key and press the [D/BAND-SET] key.

5 Verify VFO.

CHANGING THE NUMBER OF PAGING ALERTS

When you are paged, an alert sounds 7 times. This number can be changed so that the alert sounds only once.

- 1 Hold down the **[0/FUNC]** key and press the **[D/BAND-SET]** key.



- 2 Press the **[2/DOWN]** or **[3/UP]** key to select Set Mode 14.

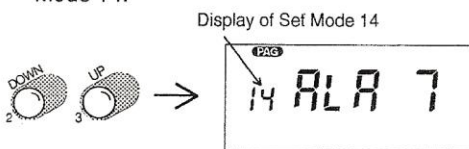

- 3 Press the **[#/V-M]** key to alter the display from 7 to 1.

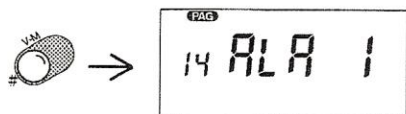

- 4 Hold down the **[0/FUNC]** key and press the **[D/BAND-SET]** key.



- 5 Verify VFO.

USING CODE SQUELCH

- 1 Set to VFO.

- 2 Make sure that the squelch condition is correct. (No noise heard from the speaker.)

- 3 Press the **[4/PG-C]** key twice.

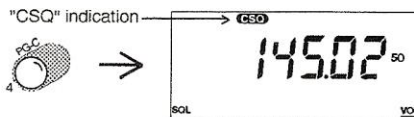
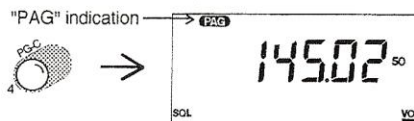

- 4 When you are called by the other party and the code matches, the squelch opens.

- 5 To call the other party, press **[PTT]**.



Paging Application (1)

When Calling a Specific Person

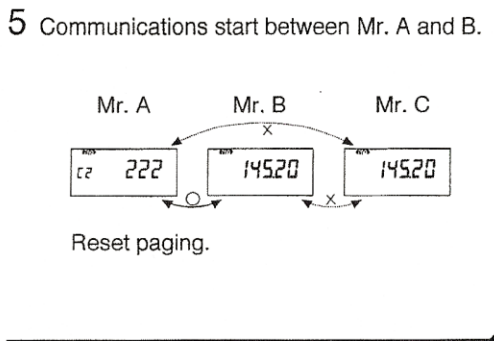
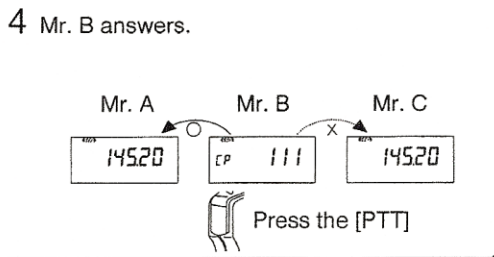
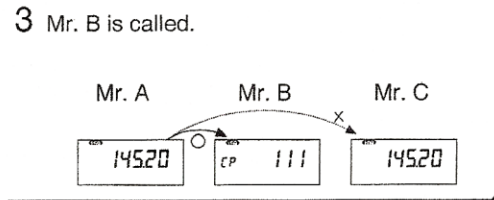
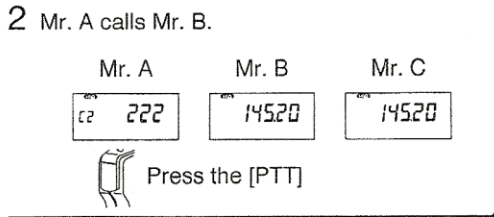
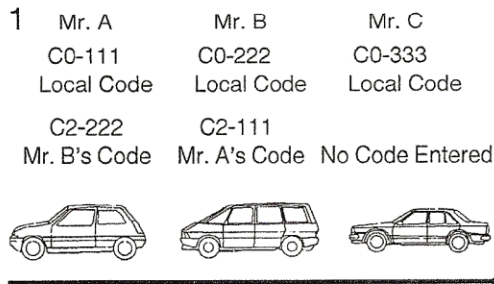

Paging Application (2)

When Calling a Group

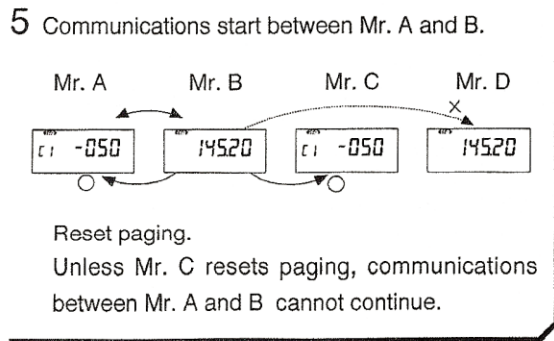
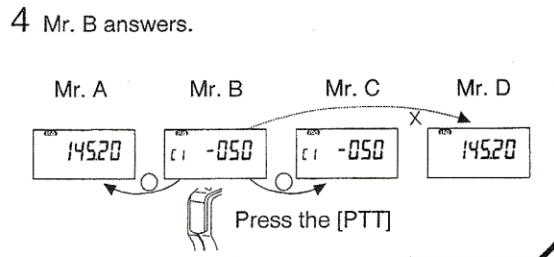
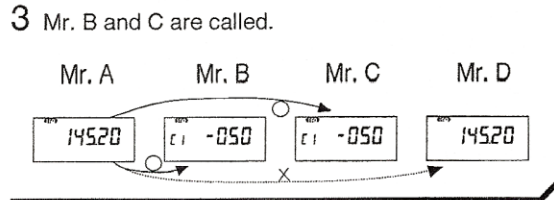
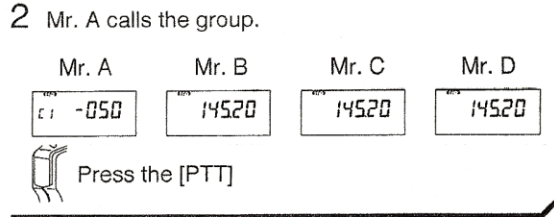
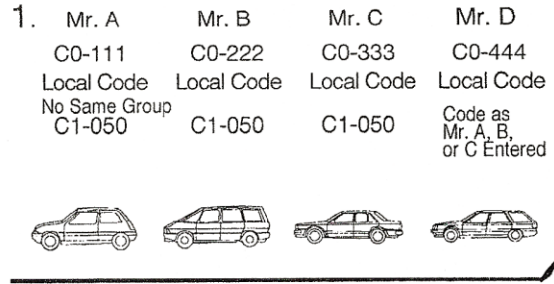

USING THE DTMF

There are two ways of sending the DTMF signal.

The first method is to press and hold the [PTT] switch while inputting the signals.

The second method is to send a DTMF code that has been stored in memory.

- ◆ To send the DTMF signal with [PTT] held down:
1. Press the desired keys (0 through 9, A through D, *, and #.) with [PTT] held down.

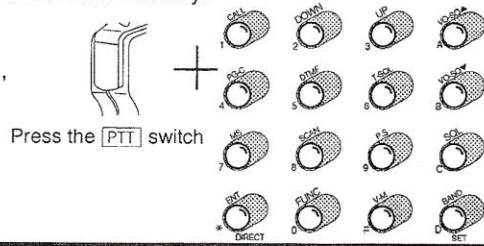

- ◆ The DTMF signal is sent only while the key is pressed.

About Storing and Displaying the DTMF Code

- A DTMF signal of up to 15 digits can be stored in the DTMF exclusive memory. The 15-digit DTMF signal is divided into three 5-digit blocks.

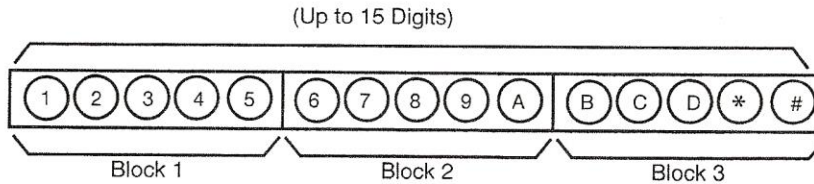

- In the following manner, you can confirm which block is being displayed on the display block:

When Block 1 Is Called

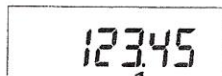

Block 1 Displayed

When Block 2 Is Called

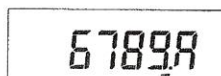

Block 2 Displayed

When Block 3 Is Called

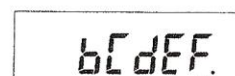

Block 3 Displayed

- There are ten exclusive memories. Storing the DTMF signal allows you to operate more easily. The storeable characters include 0 through 9, A through D, *, and #. The characters appear as follows on the display block.

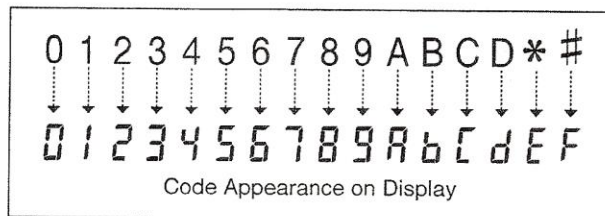

STORING THE DTMF CODE

1 Set to VFO.

2 Press the **[0/FUNC]** key and press the **[5/DTMF]** key.

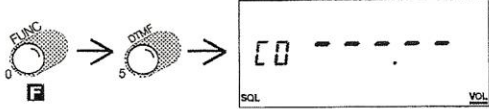

3 Press the **[2/DOWN]** or **[3/UP]** key to select the memory address (C0 to C9) for storage of the code.

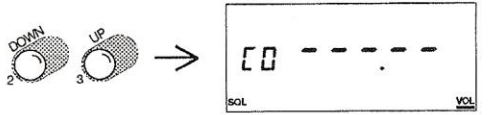

4 Press the **[*/ENT-DIRECT]** key.



5 Confirm that the display block is ready to accept an entry of the 1st character.

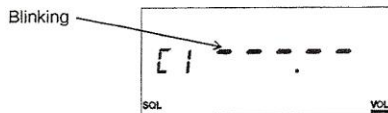

6 Using the keypad, enter the code as characters 1 through 15.

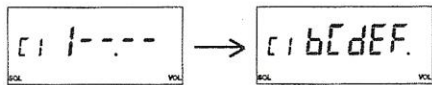

7 To return to VFO, press the **[0/FUNC]** key and press the **[5/DTMF]** key.

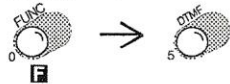

◆ When the code you enter is shorter than 15 characters, pressing **[PTT]** enters the code so far.

SENDING THE STORED DTMF CODE

1 Select the main-band, press the **[D/BAND-SET]** key.

2 Set to VFO.

3 Press the **[5/DTMF]** key.



4 Confirm that "DTMF" is shown on the display block. (DTMF mode has been set.)

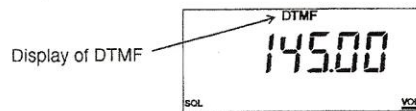

5 With **[PTT]** held down, press the stored "DTMF" code you want to send, using the keys "0" through "9". (This operation sends the stored DTMF code)

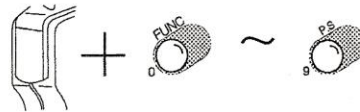

6 To erase the "DTMF" display, press the **[5/DTMF]** key.



◆ When "DTMF" is displayed, the DTMF tones corresponding to the 16 keys cannot be output.

CHANGING THE DTMF CODE IN MEMORY

You can change the DTMF code stored in the DTMF exclusive memory.

- 1 Press the **[0/FUNC]** key and press the **[5/DTMF]** key.

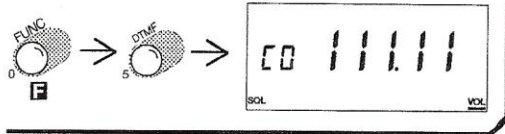

- 2 Press the **[2/DOWN]** or **[3/UP]** key to select the memory location containing the DTMF code you wish to change.

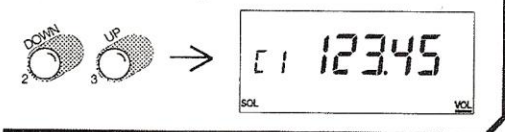

- 3 Press the **[*ENT-DIRECT]** key.



- 4 Confirm that the display block is ready to accept an entry of the 1st character.

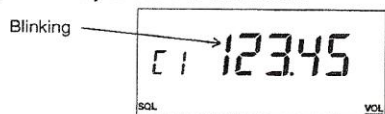

- 5 Using the keypad, enter the code from its 1st through 15th character.

- 6 To return to VFO, press the **[0/FUNC]** key and press the **[5/DTMF]** key.

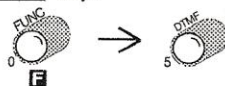

- ◆ When you alter the code, the full code must be re-entered.
- ◆ For a character you do not want to alter, enter the same character.
- ◆ When a new code is shorter than an old one, press the **[PTT]** switch halfway. The subsequent portion of the code will be deleted.

CONFIRMING THE STORED DTMF CODE

- 1 Press the **[0/FUNC]** key and press the **[5/DTMF]** key.

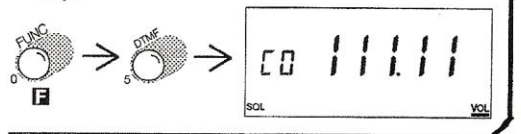

- 2 Press the **[2/DOWN]** or **[3/UP]** key to select the memory address of the code you want to confirm.

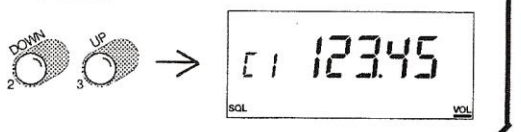

- 3 Press the **[0/FUNC]** key.



- 4 Press the **[2/DOWN]** or **[3/UP]** key to confirm the memory contents. The display will scroll through the entire code.

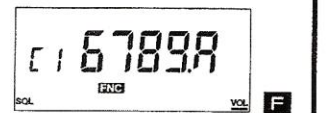

- 5 To return to VFO, press the **[0/FUNC]** key and press the **[5/DTMF]** key.

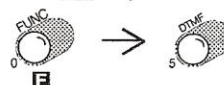

ERASING THE STORED DTMF CODE

1 Set to VFO.

2 Press the **[0/FUNC]** key and press the **[5/DTMF]** key.

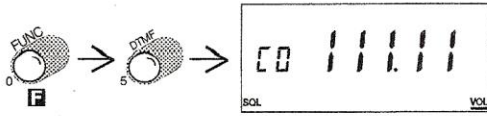

3 Press the **[2/DOWN]** or **[3/UP]** key to select the memory address whose contents you want to erase.

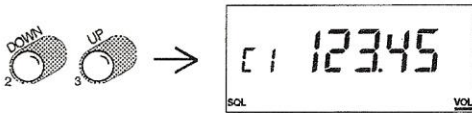

4 Press the **[*/ENT·DIRECT]** key.



5 Confirm that the display block is ready to accept an entry of the 1st digit. However, do not enter any character.

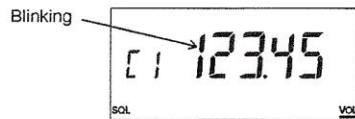

6 Press the microphone **[PTT]**. This erases the code.

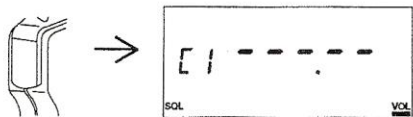

7 To return to VFO, press the **[0/FUNC]** key and press the **[5/DTMF]** key.



CHANGING THE DTMF CODE SENDING SPEED

Normally, the DTMF signal is sent at a rate of 50 msec. This rate can be changed to 100 msec.

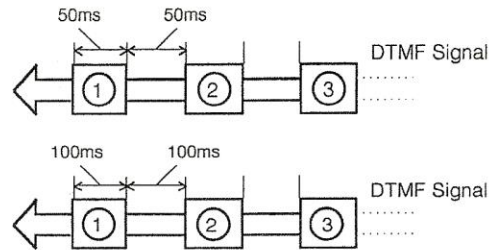

1 Hold down the **[0/FUNC]** key and press the **[D/BAND·SET]** key.



2 Press the **[2/DOWN]** or **[3/UP]** key to select Set Mode 15.

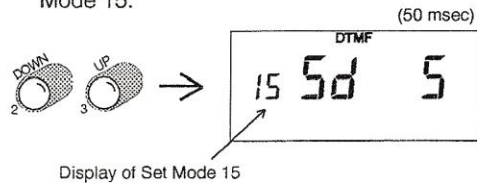

3 Press the **[#/V·M]** key to alter the display from "5" to "10".

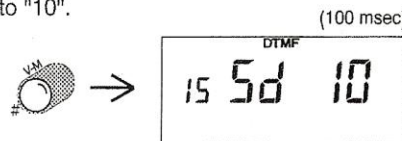

4 Hold down the **[0/FUNC]** key and press the **[D/BAND·SET]** key.

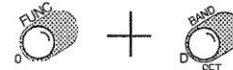

5 Verify VFO.



CHANGING THE DTMF TO A SINGLE TONE

Normally, two tones are sent as one DTMF signal. This can be changed so that only a single tone is sent.

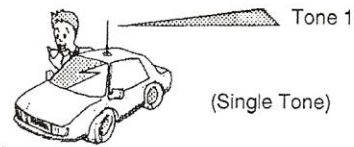
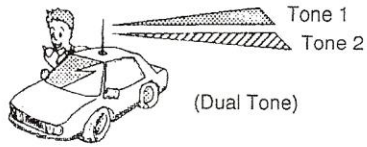

1 Hold down the **[0/FUNC]** key and press the **[D/BAND-SET]** key.



4 Hold down the **[0/FUNC]** key and press the **[D/BAND-SET]** key.



2 Press the **[2/DOWN]** or **[3/UP]** key to select Set Mode 16.

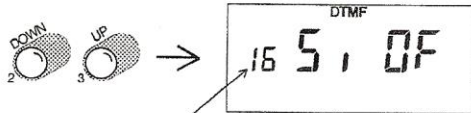

Display of Set Mode 16

5 Verify VFO.

3 Press the **[#V-M]** key to alter the display from "OF" to "on".

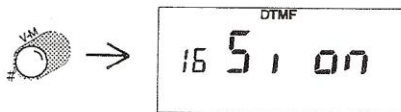

USING THE OPTIONAL CABLES (CAW560, CAW561, CAW562, CAW575, CAW576)

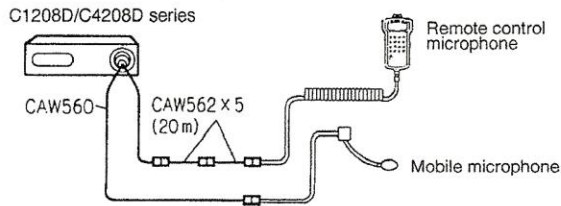

An optional dual microphone cable(CAW560) or extension cable(CAW561/CAW562) can be used as shown in the left figure. The extension cable can be connected within 20 m.

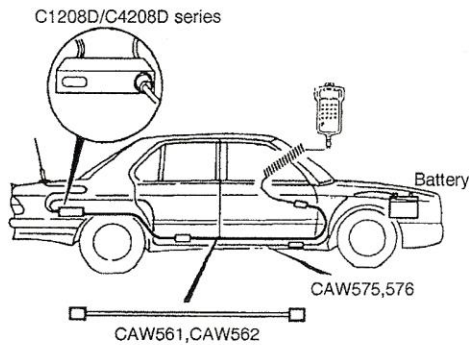

◆ The length of the dual microphone cable (CAW560) and that of a microphone's curled cord are not included.

◆ Using the extension cable, you can place the main unit in the car trunk or other location.

◆ When placing the main unit in the car trunk, or other location, it is convenient to use an optional 5-m-long extension power cable(CAW575) or 3-m-long relay power cable(CAW576).

◆ If you extend the microphone cable over 20 m, the transceiver may not function properly. The power cable should be up to 8 m long.

9,600 bps HIGH-SPEED PACKET OPERATION (G3RUH SYSTEM)

This transceiver has input and output terminals dedicated to the 9,600 bps (G3RUH) packet to allow you to enjoy high-speed packet communications without remodeling the transceiver.

1. In accordance with the connection diagram, connect the modem on hand to the transceiver.

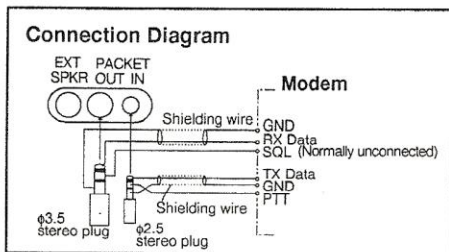

2. The G3RUH system allows you to select 16 kinds of transmitted audio signals in order to obtain higher communication reliability. For this transceiver, select the one for "TR8300" in accordance with the instruction manual for the modem. However, it may need to be changed depending on the condition of the other party.

3. TX-Audio output level be adjusted following the procedure below.

- a) Disconnect the muting circuit of the modem and expose TX-Data.
- b) Connect the PTT line to GND(case, etc.) to transmit.
- c) Make adjustment with the output level control knob of the modem so that a modulation meter will indicate a frequency deviation of ± 3 to 4 kHz.

When the modulation meter is not available, prepare a reception monitoring transceiver and make adjustment so that a receiving sound upon modulation at the modem will be reduced to about half as much as a noise generated when the squelch is turned off.

4. Set TX DELAY of the TNC to 50 - 100.

- ◆ The GMSK system cannot be recommended for this transceiver, because a signal incoming rate comes lower.
- ◆ When you transmit through a PTT line dedicated to the packet, modulation of the microphone is not applied.
- ◆ Note that overmodulation decreases a signal incoming rate.
- ◆ Read thoroughly the instruction manuals for the modem and TNC as well.

Internal Circuits

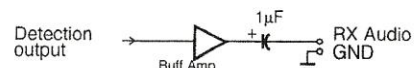

Outputs approx. 0.7V_{p-p} when a ± 2.5 kHz deviation signal is received.



A frequency deviation is approx. ± 2.5 kHz when 2V_{p-p} signal is input.

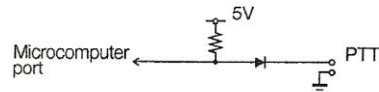

Transmits at the low level. In this case, the CMP844/A microphone is not available.



Turned to the low level upon reception (squelch is opened). Normally, unnecessary to connect.

1,200 bps PACKET OPERATION

When you want to perform 1,200 bps AFSK packet operation with this transceiver, purchase an optional dual microphone cable(CAW560) and connect it as described below.

1. In accordance with the connection diagram, connect the TNC to this transceiver.

2. Make the TNC ready for transmission. Make adjustment with the output level control knob of the TNC so that a modulation meter indicates a frequency deviation of ± 3 to 4 kHz. When the modulation meter is not available, prepare the reception monitoring transceiver and make adjustment so that a receiving sound upon modulation at the TNC will be lower than that upon modulation at a loud voice, using the microphone.

3. Set TX DELAY of the TNC to 30 to 50.

- ⚠ If TX Audio be overmodulated, receiving rate will be decrease.
- ◆ Read thoroughly the instruction manual for the TNC as well.
- ◆ The packet communication only terminals of this transceiver are exclusively designed for 9,600 bps; they are not available for 1,200 bps.

Connection Diagram

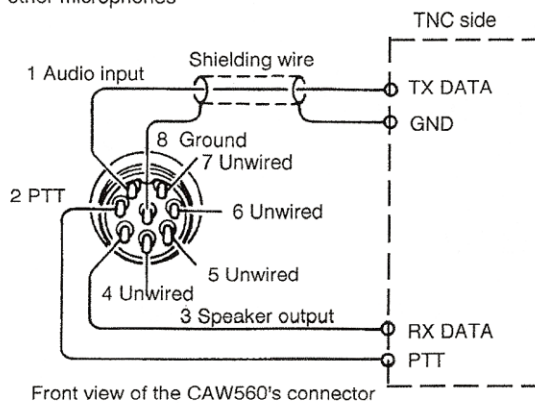
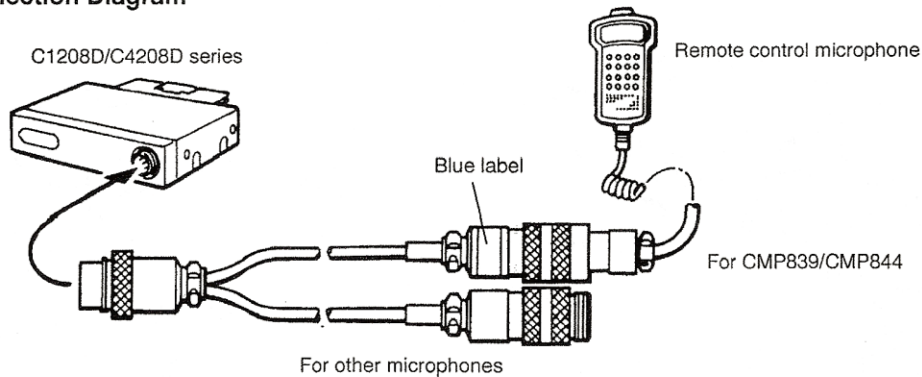

REFERENCES

TROUBLESHOOTING	68
INITIALIZATION (RESET)	69
OPTIONS	70
AFTER-SALE SERVICE	70
Specifications	71
INDEX	72

TROUBLESHOOTING

Prior to asking for our service, check the following items. When the trouble still cannot be solved by checking them, consult your dealer.

	Trouble	Major Cause and Remedy
Power System	Power cannot be turned on.	Check the fuse. Disconnected DC cord An overvoltage (DC 18 V or more) has been applied to the DC IN 13.8 V terminal. Pull out the DC IN 13.8 V plug and check the DC power source for correct voltage.
Display System	The display block is dark.	It has been dimmed by the dim control.
Reception System	Only strong signals are received.	Matching of the antenna is poor. The antenna is dislocated or loosened. The SQL is maximum. The coaxial cable is dislocated or loosened. RF squelch function has been set too high. The attenuator function is turned on.
	The squelch cannot be closed. Noise is heard.	The squelch has been turned off.
	Signals not received.	The antenna is dislocated or loosened. The coaxial cable is dislocated or loosened.
	No received audio is heard.	While the tone squelch is operating, the received audio cannot be heard unless the identical tone squelch frequency is used. Check the external speaker connections. Check the volume control position. The Paging mode or Code Squelch mode has been set.
	Received audio is too low.	Muting has been selected.
Transmission System	Transmitter power output is low.	Mismatch in antenna system. Low Power mode has been selected. The antenna is dislocated or loosened. The antenna is not connected or has loosened.
Repeater System	The repeater station cannot be accessed.	The tone burst is not transmitting. The tone frequency is different. The repeater station is far. The offset frequency is different. The shift direction has been set to "+".
	"OFF" is displayed on the display lock.	The shifted frequency is off-band.
Scan System	The equipment does not scan.	The squelch has been turned off. The SQL is minimum. Adjust SQL.
	Memory is not scanned.	Memory is not scanned unless frequencies have been stored.
Memory System	All memory cannot be cleared.	The "normal reset" method has been used to reset.
	Specific memory cannot be cleared or rewritten. Memory cannot be written to.	Memory protect has been selected

	Trouble	Major Cause and Remedy
Paging System	Paging does not function.	The CTD1200 option has not been installed. For paging, it is necessary to store the code. Your code does not match the remote code. A signal from the remote or local station does not arrive.
	"E" is displayed on the display block.	Remote code read error indication
	The code has not be set.	The CTD1200 option has not been installed.
DTMF System	No DTMF signal is sent.	The code must be set in advance. The CTD1200 option has not been installed.
Tone Squelch System	The tone squelch mode is not effected.	The CTN1200 option has not been installed.
Others	No beep sound is heard.	Beep-off has been selected.

 The CTD1200 and CTN1200 have been attached to the C1208DA/C4208DA already.

INITIALIZATION (RESET)

Resetting restores the initial conditions set by the factory.

Transceiver settings may be reset by the following four methods:

- All reset Initializes all settings such as VFO, memory, etc.
- Normal reset Initializes all settings except the memory setting. It also initializes the settings modified by the Set mode.
- Memory reset Initializes only the memory.
- Set mode reset Initializes only the set mode.

1 With the **[0/FUNC]** key held down, press the **[PWR]** switch to turn on the power.
Confirm that the display block has been reset.



3 Press the **[C/SQL]** key. This initiates reset.



2 Press the **[2/DOWN]** or **[3/UP]** key to select the resetting method.

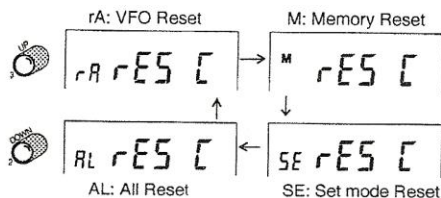

 After a reset, the respective settings have been reset. Therefore, you do not have to turn off the power once and turn it on again.

OPTIONS

CTD1200: DTMF unit
CTN1200: Tone squelch unit
CSK12: External speaker
CAW560: Dual extension cable

CAW561: Extension cable (2 m long)
CAW562: Extension cable (4 m long)
CAW575: Extension power cable (5 m long)
CAW576: Relay power cable (3 m long)

※ For proper usage of each option, read its instruction manual thoroughly.

AFTER-SALE SERVICE

<Guarantee>

The guarantee period for this product is one year.

We may charge you for a repair even during the guarantee period.

<Maintenance>

After the guarantee period expires, we will repair the product for a charge as requested. Please note that the repair may be expensive, depending on the repair.

<In Case of Trouble>

Read the "Troubleshooting" section thoroughly and check the faulty condition again. If the equipment still does not function properly, consult your dealer.

Specifications

General

Transmission/reception frequency
C1208D 144.000 to 147.995 MHz
(430.000 to 439.995 MHz receive only)
C1208DS 144.000 to 145.995 MHz
(430.000 to 439.995 MHz receive only)
C1208DA 144.000 to 147.995 MHz
(420.000 to 449.995 MHz receive only)
C4208D 430.000 to 439.995 MHz
(144.000 to 147.995 MHz receive only)
C4208DS 430.000 to 439.995 MHz
(144.000 to 145.995 MHz receive only)
C4208DA 420.000 to 449.995 MHz
(144.000 to 147.995 MHz receive only)
Transmission type F1, F2, F3
Rated voltage 13.8 V DC \pm 15%
Current consumption
At transmit (Hi) 11.0 A
At transmit (Mid) 5.2 A
At transmit (Low) 3.8 A
At wait and receive 0.5 A
Microphone input impedance 600 Ω
Low-frequency output impedance 4 Ω
Antenna impedance 50 Ω
Operating temperature range - 20°C to + 60°C
Frequency stability
C1208D, C1208DS, C1208DA \pm 10 ppm
C4208D, C4208DS, C4208DA \pm 3 ppm
Antenna connector
C1208D, C1208DS, C1208DA, C4208DA
..... M type(with cable)
C4208D, C4208DS N type(with cable)
Grounding method Negative grounding
Main unit dimensions : (Width x Height x Depth)
..... 140 x 30 x 147 mm
Weight 750 g

Reception

Receiving system Double superheterodyne
Intermediate frequency
1st IF 23.05 MHz(Lower)
2nd IF 455 kHz(Lower)
Receiving sensitivity (12 dB SINAD)
..... - 8 dB μ (0.201mV)
Selectivity 12 kHz or more(-6 dB)
..... 24 kHz or more(-60 dB)
Squelch opening sensitivity .. - 11 dBm (0.141mV)
Low-frequency output 3.0 W(at 10 % distortion)
S/N ratio at 0.5 mV input 30 dB or more

Transmission

Transmission output power
C1208D, C1208DS, C1208DA
Hi 50W
Mid 10W
Low 3W
C4208D, C4208DS, C4208DA
Hi 40W
Mid 10W
Low 3W
Modulation method Reactance modulation
Max. frequency deviation \pm 5 kHz
Spurious radiation strength - 60 dB
Modulation distortion
..... 3 % or less(at 70 % modulation)

 ♦The specifications and appearance of this transceiver are subject to change without prior notice due to improvement.

INDEX

1 MHz scan	36	Repeater	42
All reset	69	Reset	69
All scan	36	Reverse	44
Antenna	8	RF meter	10,25
APO	26	RF squelch	24
Attenuator	17	Scan	34
Band	14	Set mode	Front cover reverse,18
Beep sound	17,50	Set mode reset	69
Block	39	S meter	10
Block memory scan	39	Squelch	14
Bracket	5	Squelch-off	14
Busy scan	40	Subband	14
Call frequency	22	Time out timer	48
Code squelch	57	Tone encoder	52
Dimmer	49	Tone squelch	53
Direct input	21	Transmitting	15
Display	10	Transmit power	25
Frequency band	14	VFO	15
Frequency step	20	VFO reset	69
Function mode	Front cover reverse,16	Volume	13
Group code	54,55		
High power	25		
Hold scan	40		
Individual code	54		
Key lock	23		
Low power	25		
Main band	14		
Medium power	25		
Memory	28		
Memory reset	69		
Memory scan	38		
Muting	49		
Offset Frequency	42,45		
Optional cable	64		
Paging	56		
Pause scan	40		
Power supply cable	6		
Priority	31		
Priority scan	38		
Program scan	37		
PTT lock	48		
Receiving	15		

DTMF Tone Frequencies

	1209 Hz	1336 Hz	1477 Hz	1633 Hz
697 Hz	1	2	3	A
770 Hz	4	5	6	B
852 Hz	7	8	9	C
941 Hz	*	0	#	D

Example:

Pressing the number 5 on the DTMF pad would send the row tone 770 Hz and the column tone 1336 Hz.

Hombrew CAW560 Cable Pinouts

Mic Auxiliary Connector			Standard Auxiliary Connector			Standard Radio Connector		
<u>Pin</u>	<u>Color</u>	<u>Signal</u>	<u>Pin</u>	<u>Color</u>	<u>Signal</u>	<u>Pin</u>	<u>Color</u>	<u>Signal</u>
1			1	Green	Tx Audio	1	White	Tx Audio
2			2	Black	PTT	2	Black	PTT
3	Brown	Rx Audio	3	Brown	Rx Audio	3	Brn/Blk	Rx Audio
4			4	Red	SW 13.8V	4	Red	SW 13.8V
5			5	Yellow	Clock	5	Orange	Clock
6	Black	PTT	6	Orange	On/Off	6	Blue	On/Off
7	Drain	Ground	7	Blue	Data	7	Green	Data
8	Green	Tx Audio	8	Drain	Ground	8	Drain	Ground

Standard C-1208DA 144MHz Transceiver
Serial # 49U060054
Power Output Measurements on August 04, 1995

Frequency	High	Medium	Low
147.995	62.00	11.10	3.80
147.000	62.00	11.10	3.70
146.000	61.00	11.00	3.75
145.000	61.00	10.75	3.70
144.000	59.00	10.10	3.70